

FEATURED MODEL

510-883 8" & 7" bowl depths

ADDITIONAL MODELS

- 510-882 Left side large bowl, 10" & 7" bowl depths
- 510-882R Right side large bowl, 7" & 10" bowl depths
- 510-883R Right side large bowl, 7" & 8" bowl depths

FEATURES

- 18 gauge, 304 series stainless steel
- 18/10 chrome/nickel content
- Long-lasting, easy-to-clean, satin polished finish
- Rear drain placement

CODE/STANDARDS COMPLIANCE

ASME 112.19.3-00
 IAPMO/UPC listed

OPTIONAL ACCESSORIES

- Sink Grids: 510-900, 510-901
- Colanders: 215-651, 510-889, 508-803
- Plate Stack: 508-812

WARRANTY

Blanco America's Platinum Series sinks feature a "NO HASSLE" LIMITED LIFETIME WARRANTY to be free of all manufacturing defects under normal use. See our complete warranty for details.

While Blanco America endeavors to provide accurate information, all dimensions are nominal, cannot be guaranteed, and are subject to change or cancellation. Blanco America assumes no responsibility for use of superseded or voided specifications.

PRODUCT SPECIFICATION

Undermount sink to be 1-3/4 bowl design, 37-13/32" in length and 20-7/8" in front-to-back depth. Sink to be made from 18 gauge, 304 series stainless steel, with 18/10 chrome/nickel content and satin polished finish. Sink to feature rear drain placement. Sink to be Blanco Model 510-883, with large bowl depth of 8" and small bowl depth of 7".



MODEL 510-883

NOMINAL DIMENSIONS

MODEL	OVERALL	CUTOUT SIZE	BOWL DEPTH LEFT	BOWL DEPTH RIGHT	DRAIN DIAMETER
510-883	37-13/32 x 20-7/8	Template provided with approximate 1/8" reveal	8	7	3-1/2

DXF cutout templates available on our web site or this specification CD.

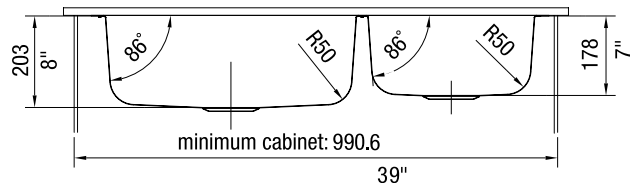
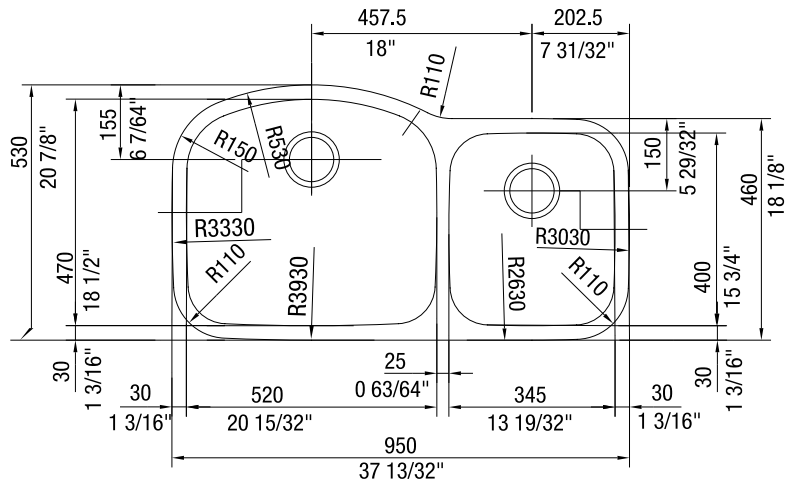

JOB INFORMATION

Job Name: _____
 Contact: _____
 Date Specified: _____
 Specifier: _____
 Contractor: _____