

**MODEL NUMBER:**

☐ **2064.724 Shower System Kit**

Includes:

- 3 Function Adjustable Handshower
- Hose
- Wall Supply
- Slide Bar

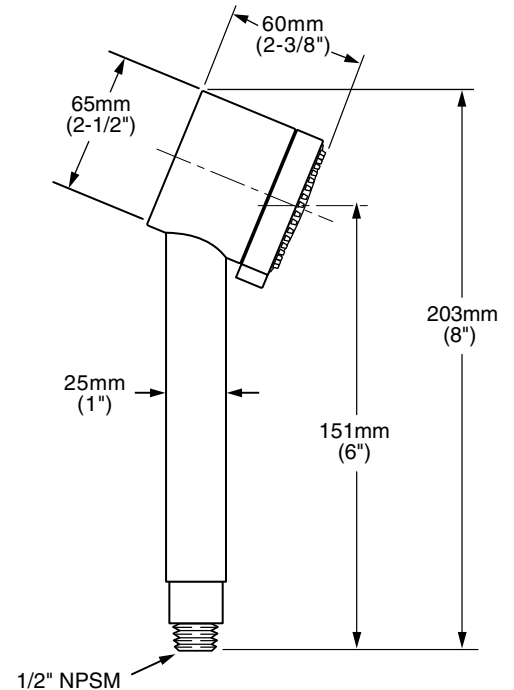
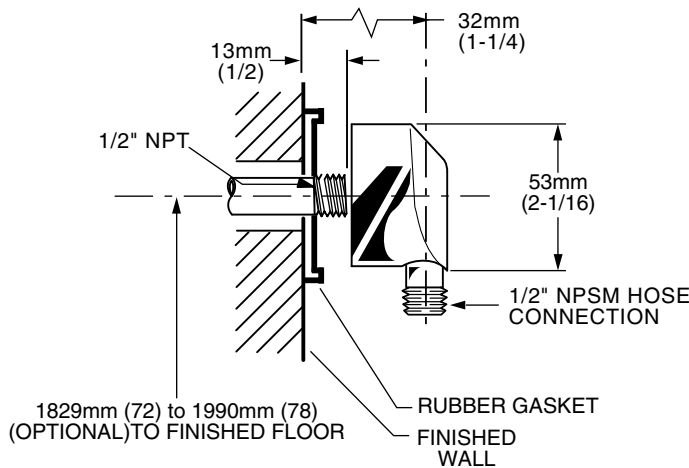

**GENERAL DESCRIPTION:**

Complete personal shower system includes: a wall supply with 1/2" NPT female inlet, 1/2" NPSM male outlet; a 59" (1500mm) shower hose; a personal shower; and a 635mm (25") Slide Bar. Personal shower with 2.5 gpm/9.5L/min. flow restrictor. Adjustable shower holder can be set at any height or position along the bar and angle up to 45°.

**PRODUCT FEATURES:**

**PERSONAL SHOWER**

**Lightweight, Ergonomic Design:** For a sure grip even with wet, soapy hands.

**Simple Spray Pattern Adjustment:** Spray patterns can be changed with a flick of the thumb.

**Variety of Spray Patterns:** Allows the user to select the type of spray best suited to their needs.

**SLIDE BAR**

**Simple Height Adjustment:** Allows positioning of the personal shower anywhere along the bar.

**SUGGESTED SPECIFICATION:**

Shower system shall feature a wall supply with 1/2" NPT female inlets, 1/2" NPSM male outlet, 59" hose, personal shower and a 635mm (25") Standard Slide Bar. Personal shower shall be ergonomically designed for a positive grip even when wet. Spray pattern adjustment shall be performed with simple movement of thumb without need to change grip on handle. Fitting shall be American Standard Model # 2064.724.\_\_\_\_.

**CODES AND STANDARDS**

Install as required to comply with local code requirements.

**ASME A112.18.1**

Product Number	Description	Finish Options	
		Polished Chrome	PVD Satin
		002	295
2064.724	Shower System Kit. Contains handshower, hose, wall supply and slide bar.		