

Veneto Venti (Compact Fluorescent)

PF400_326

1.0



GENERAL PRODUCT INFORMATION:



This product can mount to either a 4" square electrical box with round plaster ring or an octagon electrical box.

This product is suitable for indoor dry locations only.

CAUTION - RISK OF FIRE

This product requires installation by a qualified electrician. Before installing be sure to read all instructions and **TURN THE POWER TO THE ELECTRICAL BOX OFF.**

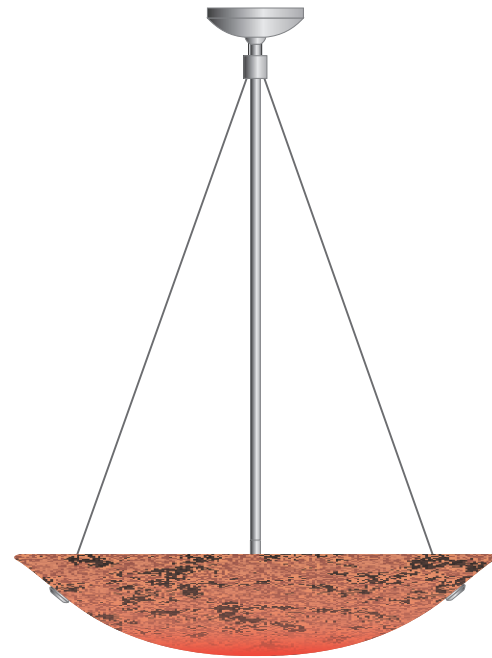

Adjust the Fixture Height

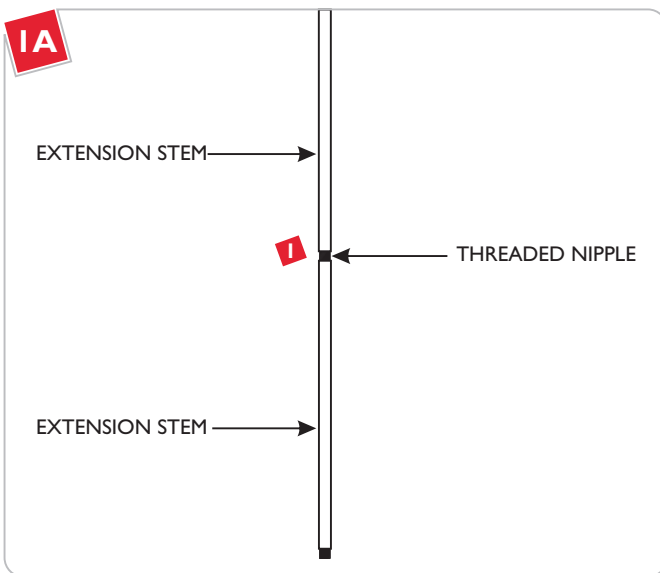

NOTE: Use a 24" extension stem for the minimum 33" overall height. To extend the fixture height to 45", or 57", or 69", use the additional 12", or 24", or combination of 12" and 24" provided extension stems respectively. The extension stems are not field cuttable.

- 1 To combine the extension stems, simply tighten one extension stem threaded nipple completely to the back of the other extension stem.

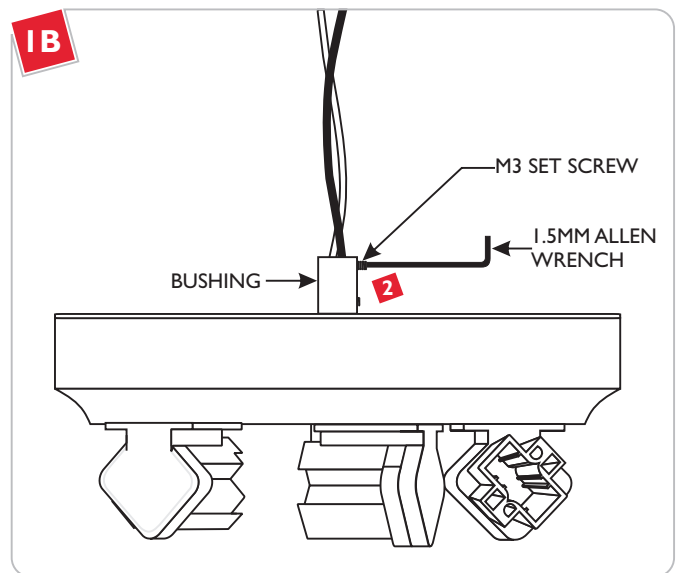

- 2 Loosen (**Do Not Remove**) the top M3 set screw on the bushing with the provided 1.5MM Allen wrench.

Install the Lamp and Glass Shade

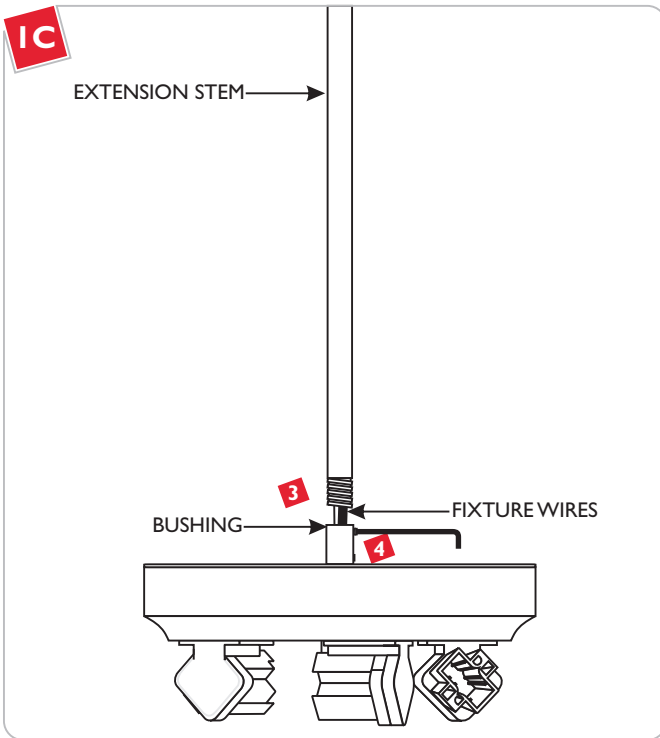

- 3 Feed the fixture wires through the extension stem(s). Tighten the extension stem completely to the socket bushing.
- 4 Tighten the top M3 set screw on the bushing with the 1.5MM Allen wrench.

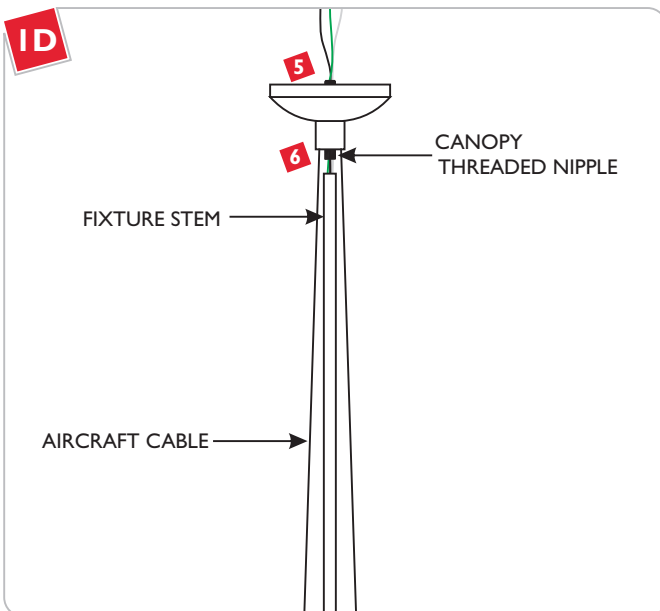

- 5 Feed the fixture wires coming out of the fixture stem through the canopy threaded nipple.
- 6 Tighten the fixture stem completely to the canopy threaded nipple. Make sure that the aircraft cables do not get tangled up.

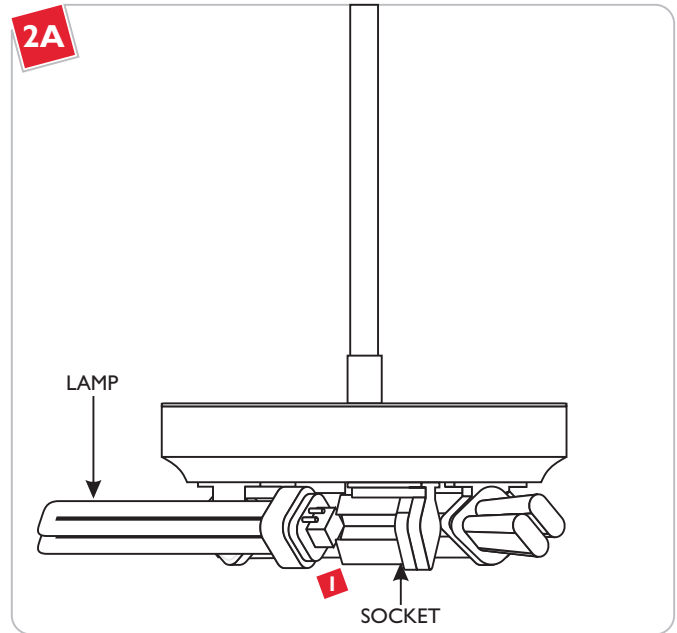

CAUTION: To reduce the risk of a burn or electric shock during relamping, disconnect the power to the fixture.

Use **MAX 26** Watt Type Quad Tube
G24q-3 Base Compact Fluorescent Lamp 
With Each Socket.

- 1 For each socket, install the lamp by pushing the lamp pins completely into the socket holes.

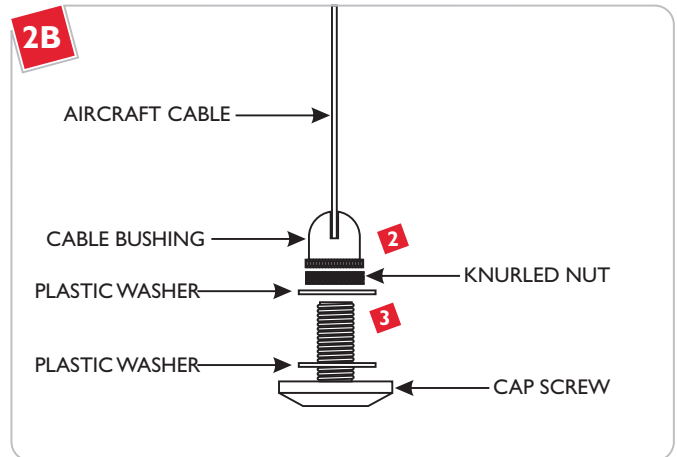

- 2 Remove the cap screw from the cable bushing.
- 3 Remove the knurled nut and one of the plastic washers from the cap screw.

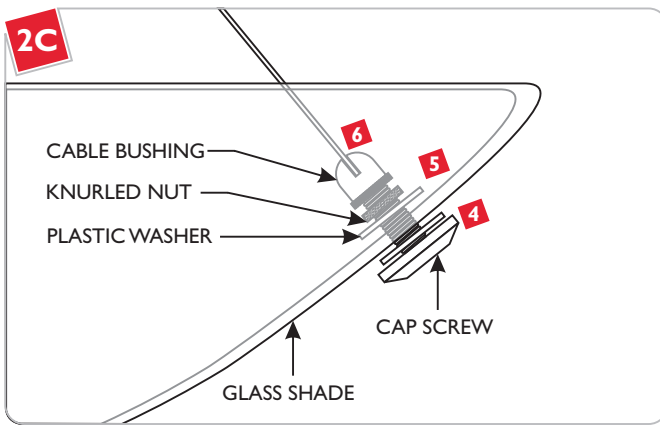

- 4 From outside of the glass shade, insert the cap screw through one glass shade hole.
- 5 Place the second plastic washer onto the cap screw and finger tighten the knurled nut to secure the cap screw in place.
- 6 Screw the cable bushing completely to the cap screw.
- 7 Repeat steps 4 through 6 for the remaining glass shade holes.

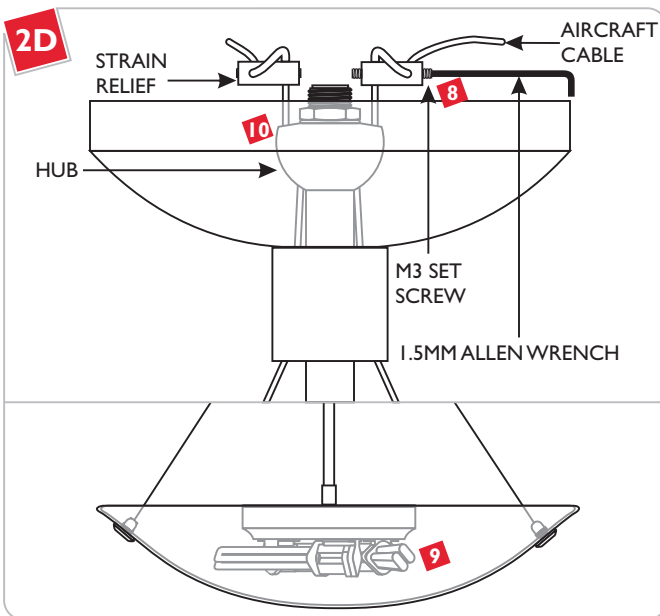

- 8 For each strain relief, loosen (**Do Not Remove**) the M3 set screws with the provided 1.5MM Allen wrench.
- 9 Adjust the aircraft cable so that there is enough space between the bottom of the lamps and the inside glass shade.
- 10 Adjust the marked aircraft cables in the strain relief and make sure that the strain relief sits against the hub; tighten the two M3 set screws with the 1.5MM Allen wrench.

CAUTION: These set screws must be very tight to secure the glass in place. Failure to do so may cause the glass shade to fall.

- 11 For a nice and neat look, trim off excess aircraft cables coming out of the strain reliefs.

Install the Fixture

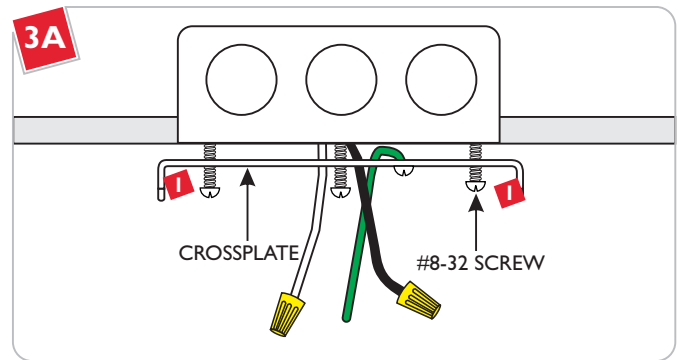

- 1 Mount the crossplate to the electrical box with the four provided #8-32 screws.

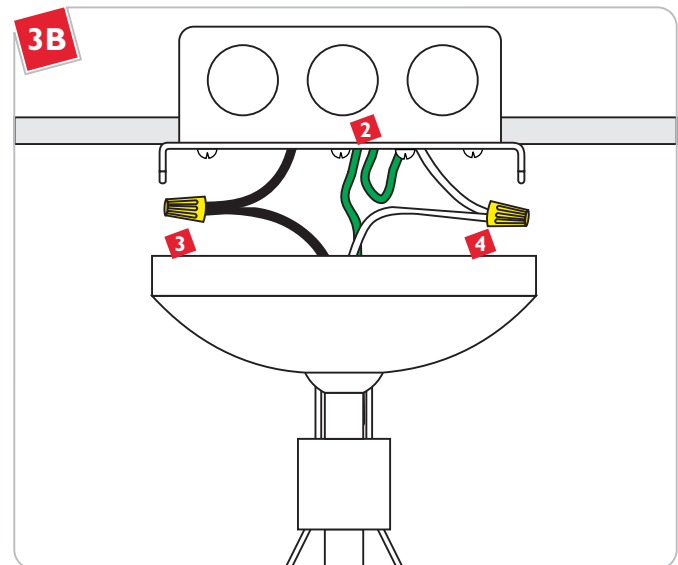

NOTE: To ease the installation, it is recommended to remove the glass shade by unscrewing the cable bushings (refer to drawing 2C).

- 2 Connect the fixture bare wire and the crossplate green wire to the ground in accordance with local electrical codes.
- 3 Connect the fixture black wire to the hot power line wire with a wire nut.
- 4 Connect the fixture white wire to the neutral power line wire with a wire nut.

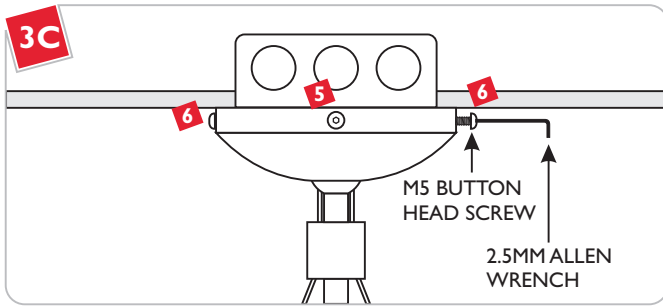

- 5** Place all wire and wire nut connections inside the electrical box.
- 6** Align the canopy holes with the crossplate holes. Secure the canopy in place by tightening the four M5 button head screws with the provided 2.5MM Allen wrench.
- 7** Tighten the three aircraft cable bushings to the glass shade cap screws (refer to step 6 and figure 2C on page 3).

SAVE THESE INSTRUCTIONS!



7400 Linder Ave, Skokie, IL 60077

800.323.3226 - 847.626.6300

www.lblighting.com

© 2008 LBL Lighting. All rights reserved. The "LBL Lighting" graphic is a registered trademark of LBL Lighting. LBL Lighting reserves the right to change specifications for product improvements without notification.

A Generation Brands Company