

Installation Instructions / Warranty

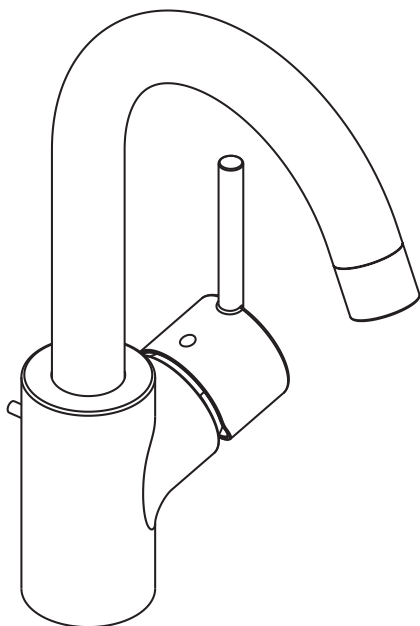

Talis
32070XX1

hansgrohe

Talis Lavatory Faucet 32070XX1

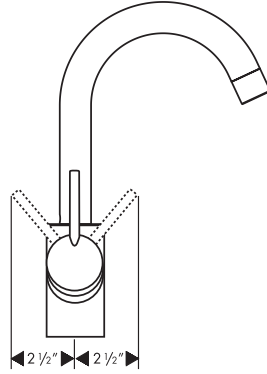
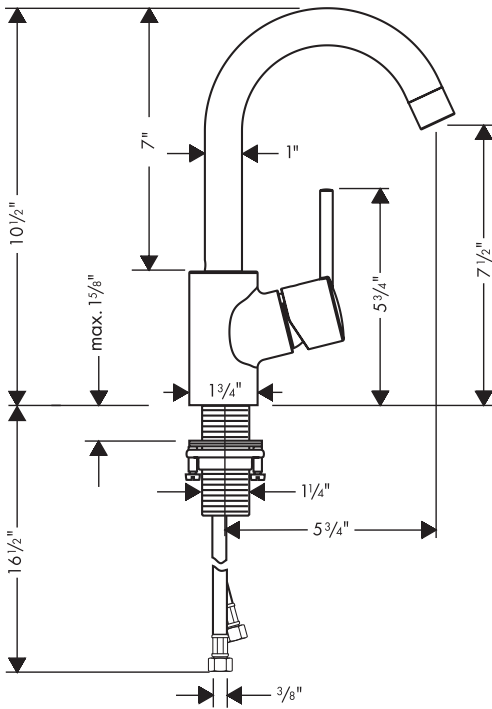

Caution:
Do not bend or twist
the supply hoses!

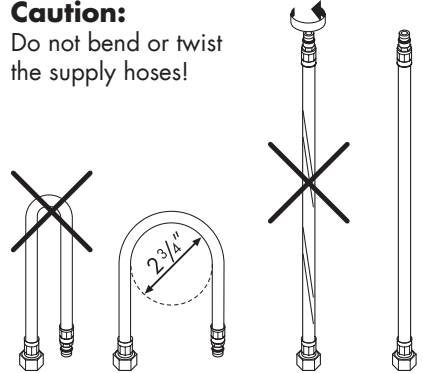

Technical Information

Recommended water pressure	14.7 - 72.5 psi
Max. water pressure	145 psi
Recommended hot water temp.	120° - 140° F*
Max. hot water temp	165° F*
Hole size in mounting surface	1-1/2"
Max. mounting surface depth	2 3/8"
Flow rate	1.5 gpm
Cartridge with high temperature limit stop	
3/8" supply hoses	

*Please know and follow all applicable local plumbing codes when setting the temperature on the water heater.

Installation Considerations

- For best results, Hansgrohe recommends that this unit be installed by a licensed, professional plumber.
- Please read over these instructions thoroughly before beginning installation. Make sure that you have all tools and supplies needed to complete the installation.

Installation

Position the faucet and sealing ring on the mounting surface.

Install the friction washer, metal washer and mounting nut.

Tighten the mounting nut by hand.

Tighten the tensioning screws.

Install the pull rod.

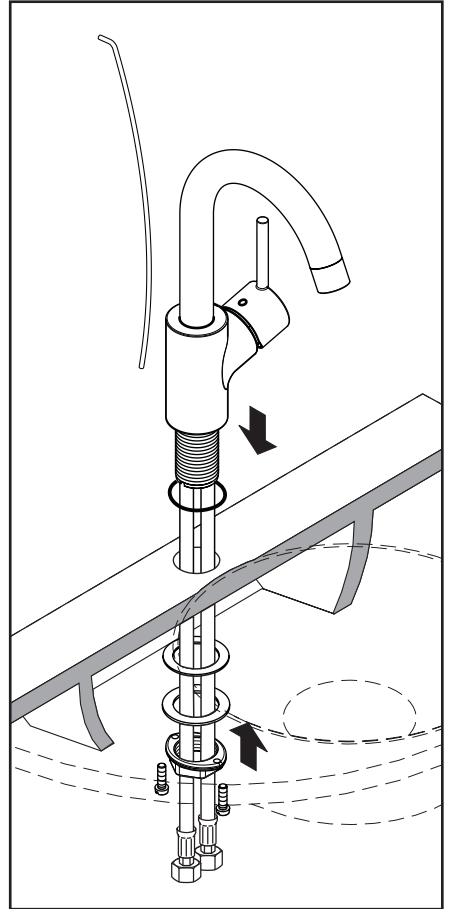

Connect the supply hoses to the stops.



Use two wrenches, as shown in the diagram, to prevent hose twisting.

Install the pop-up drain.

Turn on the water. Check all connections for leaks.

Set the high temperature limit stop, if desired.

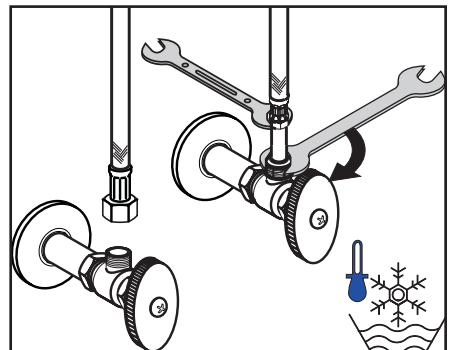

Install the pop-up drain

Remove the plunger assembly.

Unscrew the drain outlet flange from the tee.

Unscrew the tailpiece from the tee. Wrap the threads with Teflon tape and replace.

Install the white, flexible sealing gasket to the flange. Place it in the sink outlet.

Install the black mack gasket, white friction ring and retainer nut on the flange.

Do not tighten the nut against the bottom of the sink at this time.

Thread the tee and tailpiece to the flange. The pivot must face the faucet. Turn the drain assembly if necessary.

Tighten the retainer nut.

Place the plunger assembly in the drain.

Install the horizontal rod so that the end goes through the loop in the bottom of the plunger.

Install and hand tighten the pivot ball nut.

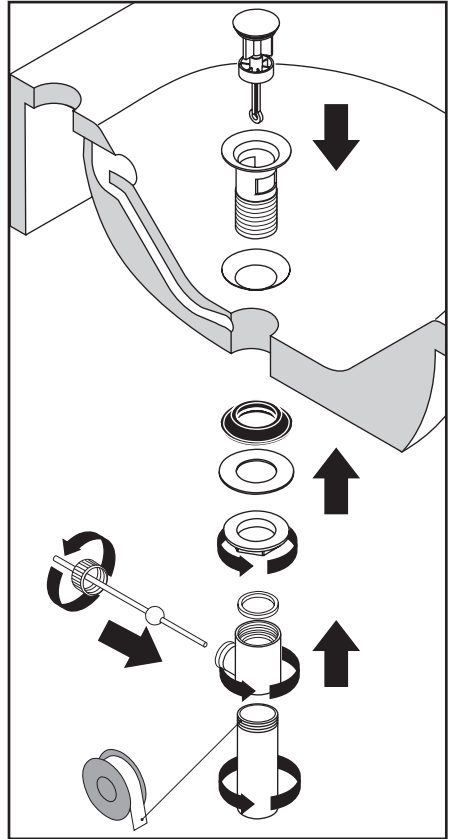

Attach the swivel connector to the end of the horizontal rod.

Attach the swivel connector to the end of the pull rod. Position as desired and tighten with a small, flat bladed screwdriver.

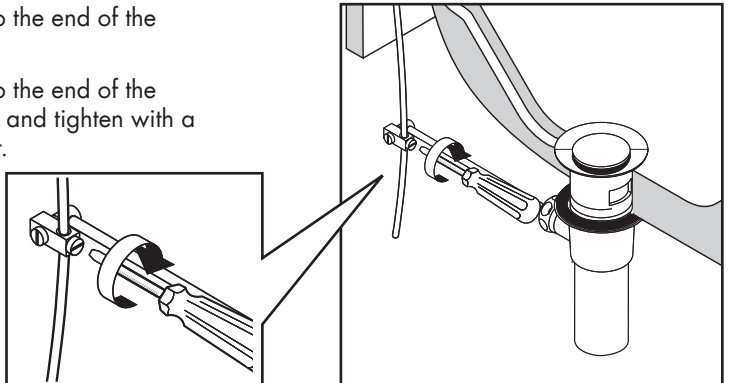

Set the High Temperature Limit Stop (optional)

Use a 4 mm Allen wrench to push the screw cover into the handle. Retrieve the screw cover when the handle is removed.

Use the 4mm Allen wrench to loosen the handle screw 4 complete revolutions.

Remove the handle.

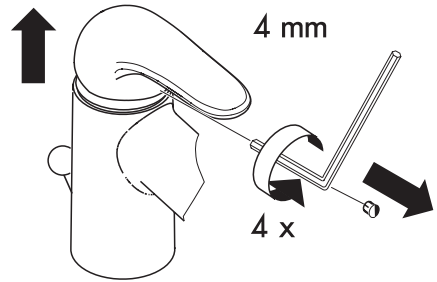

Remove the flange.

Remove the handle screw from the stem of the cartridge.

Remove the high temperature limit stop.

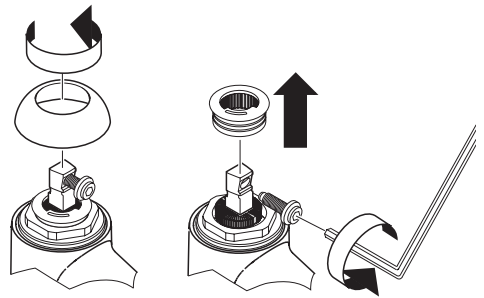

Replace the high temperature limit stop so that the pin on the cartridge is in the desired slot on the limit stop. Note: the temperatures given in the diagram assume a water heater temperature of 140° F, a cold water temperature of 50° F and a water pressure of 45 PSI.

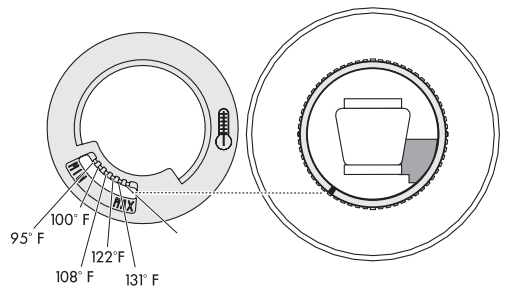

Replace the flange. Replace the handle screw. Use the Allen wrench to turn the screw 4 revolutions.

Replace the handle. Finish tightening the handle screw. Turn on the water and test the faucet.

User Instructions

Pivot the handle out to turn the water on, in to turn the water off.

Pivot the handle to the rear for warmer water, to the front for colder water.

Replacement Parts

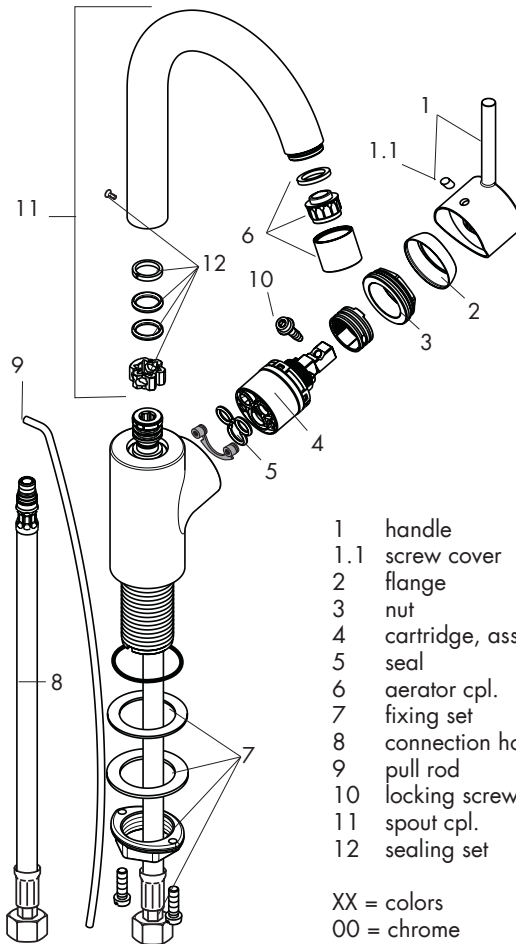

1	handle	32095XX0
1.1	screw cover	96338000
2	flange	97406XX0
3	nut	97209000
4	cartridge, assy	92730000
5	seal	95008000
6	aerator cpl.	
7	fixing set	13961000
8	connection hose 450 mm	
9	pull rod	96657XX0
10	locking screw for handle	96059000
11	spout cpl.	96521XX0
12	sealing set	92646000

XX = colors
 00 = chrome
 82 = brushed nickel

Cleaning Recommendation for Hansgrohe Products

Modern lavatory faucets, kitchen faucets, and showers consist of very different materials to comply with the needs of the market with regard to design and functionality. To avoid damage and returns, it is necessary to consider certain criteria when cleaning.

Cleaning Materials for Faucets and Showers

Acids are a necessary ingredient of cleaning materials for removing lime, however please pay attention to the following points when cleaning faucets and showers:

- Only use cleaning materials which are explicitly intended for this type of application.
- Never use cleaning materials which contain hydrochloric, formic, phosphoric, or acetic acid, as they cause considerable damage.
- Never mix one cleaning material with another.
- Never use cleaning materials or appliances with an abrasive effect, such as unsuitable cleaning powders, sponge pads, or micro fiber cloths.

Cleaning Instructions for Faucets and Showers

Please follow the cleaning material manufacturer's instructions. In addition, pay attention to the following points:

- Clean the faucets and showers as and when required
- Use the amount of cleaning product and the amount of time recommended by the manufacturer. Do not leave the cleaner on the fixture longer than necessary.
- Regular cleaning can prevent calcification.
- When using spray cleaners, spray first onto a soft cloth or sponge. Never spray directly onto the faucet as droplets can enter openings and gaps and cause damage.
- After cleaning, rinse thoroughly with clean water to remove any cleaner residue.

Important

Residues of liquid soaps, shampoos, and shower foams can also cause damage, so rinse with clean water after using.

Please note: if the surface is already damaged, the effect of cleaning materials will cause further damage.

Components with damaged surfaces must be replaced or injury could result.

Damage caused by improper treatment is not covered under the warranty.

Limited Lifetime Consumer Warranty

This product has been manufactured and tested to the highest quality standards by Hansgrohe, Inc. ("Hansgrohe"). This warranty is limited to Hansgrohe products which are purchased by a consumer in the United States after March 1, 1996, and installed in either the United States or Canada.

WHO IS COVERED BY THE WARRANTY

This warranty extends to the original consumer purchaser only. This warranty is non-transferable.

WHAT IS COVERED BY THE WARRANTY

This warranty covers only your Hansgrohe manufactured product. Hansgrohe warrants this product against defects in material or workmanship as follows: Hansgrohe will repair at no charge for parts only or, at its option, replace any product or part of the product that proves defective because of improper workmanship and/or material, under normal installation, use, service and maintenance. If Hansgrohe is unable to provide a replacement and repair is not practical or cannot be timely made, Hansgrohe may elect to refund the purchase price in exchange for the return of the product.

LENGTH OF WARRANTY

Replacement or repaired parts of products will be covered for the term of this warranty as stated in the following two sentences. If you are a consumer who purchased the product for use primarily for personal, family, or household purposes, this warranty extends for as long as you own the product and the home in which the product is originally installed. If you purchased

the product for use primarily for any other purpose, including, without limitation, a commercial purpose, this warranty extends only (i) for 1 year, with respect to Hansgrohe and Commercial products, and (ii) for 5 years, with respect to AXOR products.

THIS WARRANTY DOES NOT COVER, AND HANSGROHE WILL NOT PAY FOR:

- A. Conditions, malfunctions or damage not resulting from defects in material or workmanship.
- B. Conditions, malfunctions or damage resulting from (1) normal wear and tear, improper installation, improper maintenance, misuse, abuse, negligence, accident or alteration, or (2) the use of abrasive or caustic cleaning agents or "no-rinse" cleaning products, or the use of the product in any manner contrary to the product instructions. (3) Conditions in the home such as excessive water pressure or corrosion.
- C. Labor or other expenses for the disconnection, deinstallation, or return of the product for warranty service, or for installation or reinstallation of the product (including but not limited to proper packaging and shipping costs), or for installation or reinstallation of the product.
- D. Accessories, connected materials and products, or related products not manufactured by Hansgrohe.

TO OBTAIN WARRANTY PARTS OR INFORMATION

Contact your Hansgrohe retailer, or contact Technical Service at:

Hansgrohe Inc.
1492 Bluegrass Lakes Parkway
Alpharetta GA 30004
Toll-free (800) 334-0455.

In requesting warranty service, you will need to provide

- 1. The sales receipt or other evidence of the date and place of purchase.
- 2. A description of the problem.
- 3. Delivery of the product or the defective part, postage prepaid and carefully packed and insured, to Hansgrohe Inc. 1492 Bluegrass Lakes Parkway, Alpharetta, Georgia 30004, Attention: Technical Service, if required by Hansgrohe.

When warranty service is completed, any repaired or replacement product or part will be returned to you postage prepaid.

EXCLUSIONS AND LIMITATIONS

REPAIR OR REPLACEMENT (OR, IN LIMITED CIRCUMSTANCES, REFUND OF THE PURCHASE PRICE) AS PROVIDED UNDER THIS WARRANTY IS THE EXCLUSIVE REMEDY OF THE PURCHASER. HANSGROHE NEITHER ASSUMES NOR AUTHORIZES ANY PERSON TO CREATE FOR IT ANY OBLIGATION OR LIABILITY IN CONNECTION WITH THIS PRODUCT.

HANSGROHE SHALL NOT BE LIABLE TO PURCHASER OR ANY PERSON FOR ANY INCIDENTAL, SPECIAL, OR CONSEQUENTIAL DAMAGES, ARISING OUT OF BREACH OF THIS WARRANTY OR ANY IMPLIED WARRANTY (INCLUDING MERCHANTABILITY).

Some States do not allow the exclusion or limitation of incidental or consequential damages, so the above limitation or exclusion may not apply to you. This warranty gives you specific legal rights, and you may have other rights which vary from State to State. You may be required by law to give us a reasonable opportunity to correct or cure any failure to comply before you can bring any action in court against us under the Magnuson-Moss Warranty Act.

PRODUCT INSTRUCTIONS AND QUESTIONS

Upon purchase or prior to installation, please carefully inspect your Hansgrohe product for any damage or visible defect. Prior to installing, always carefully study the enclosed instructions on the proper installation and the care and maintenance of the product. If you have questions at any time about the use, installation, or performance of your Hansgrohe product, or this warranty, please call or write to us or call us toll-free at 800 334 0455.

hansgrohe

Hansgrohe, Inc. • 1490 Bluegrass Lakes Parkway • Alpharetta, GA 30004
Tel. 770-360-9880 • Fax 770-360-9887

www.hansgrohe-usa.com