

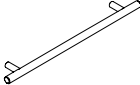



ASSEMBLY INSTRUCTIONS

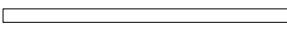

Thank you for purchasing Jesper products! We trust you will be satisfied with it for many years to come. Before you discard the packing material and start assembly, please take time to identify all hardware and parts needed for completion. As you unpack, please place all parts on a clean carpeted or padded area to avoid accidental damage.

HARDWARE	MODEL NO.		
	1/32/20/2	1/32/20/0	1/63/20/2
 985173	d x 2		d x 2
 long 980727	e x 4		e x 4
 980915	f x 8		f x 8
 980917	h x 4		h x 4
 985174		i x 2	i x 2
 short 980728		j x 2	j x 2

PARTS LIST AND INSTRUCTIONS

1/32/20/2

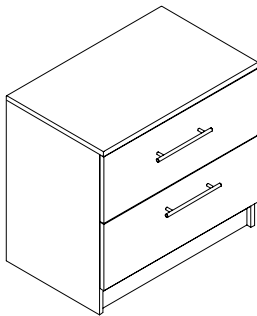

1/32/20/0

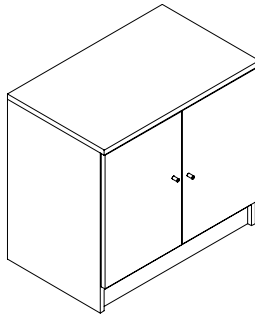

1/63/20/2

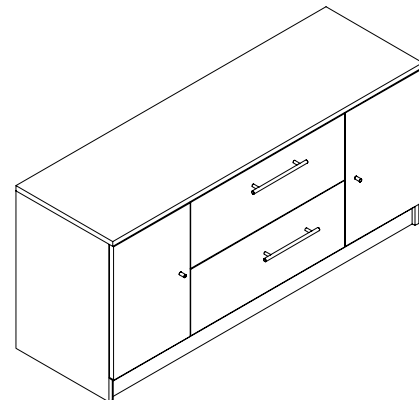

Maintenance!

Melamine: Clean using a mild non detergent soap solution and wipe off excess with a dry soft cloth.

Aluminum and other metal parts: Clean using a mild non detergent soap solution and wipe off with a clean damp cloth. Use rubbing alcohol for stubborn stains.

Never use solvents for cleaning of Melamine or Metal Furniture.

Location: Avoid placing furniture in moist areas or in direct sunlight.

Should you need any other information, please contact the retail store where you purchased the products or Jesper Office Inc.

info@jesperoffice.com

Phone 908-218-4200 Fax 800-JESPER-2

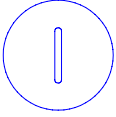

1/32/20/2

1/32/20/0

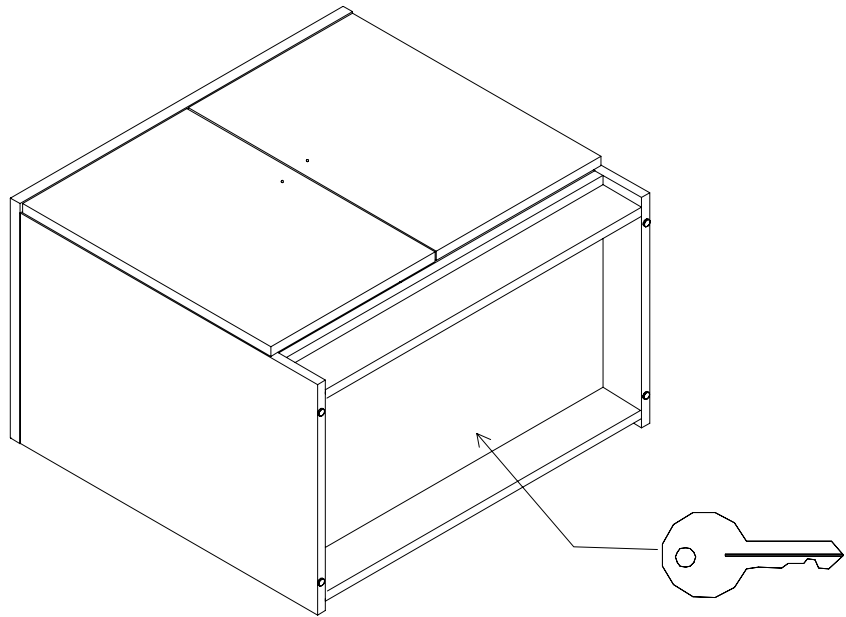

1/63/20/2

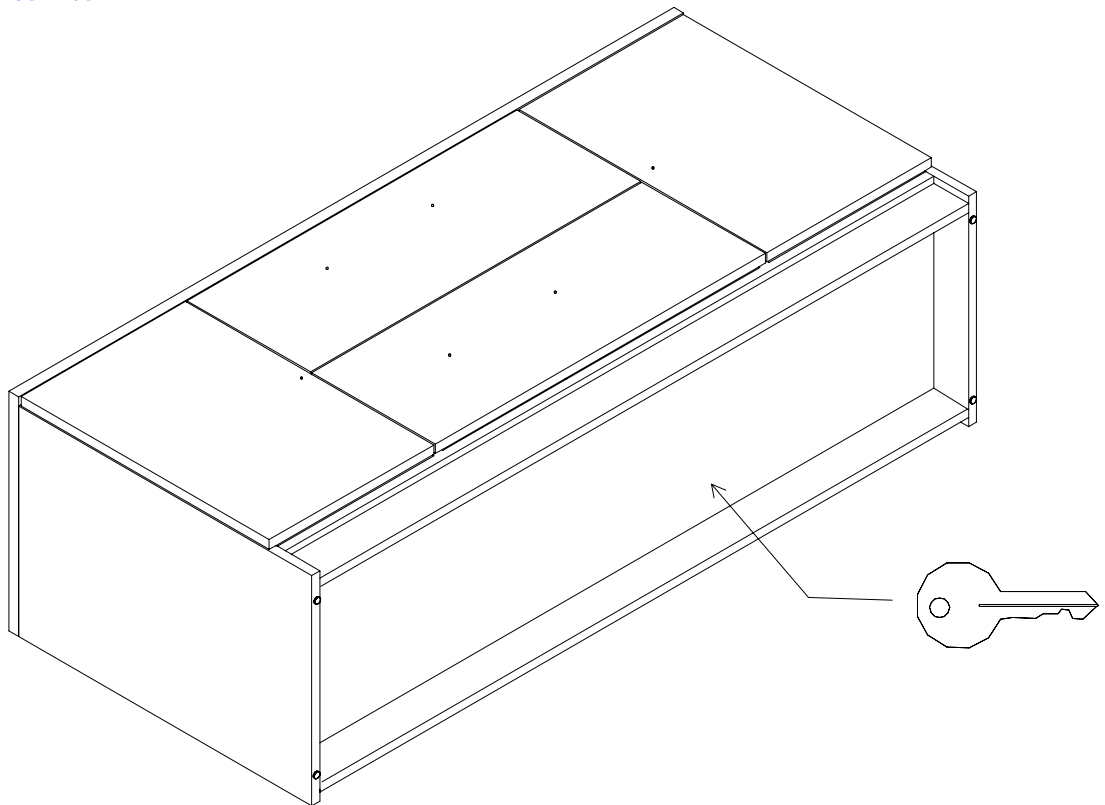

2

1/32/20/2

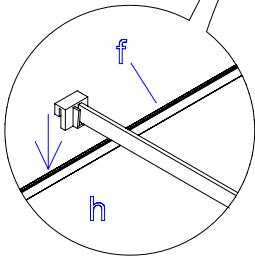
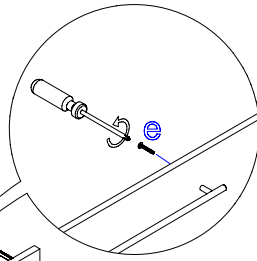
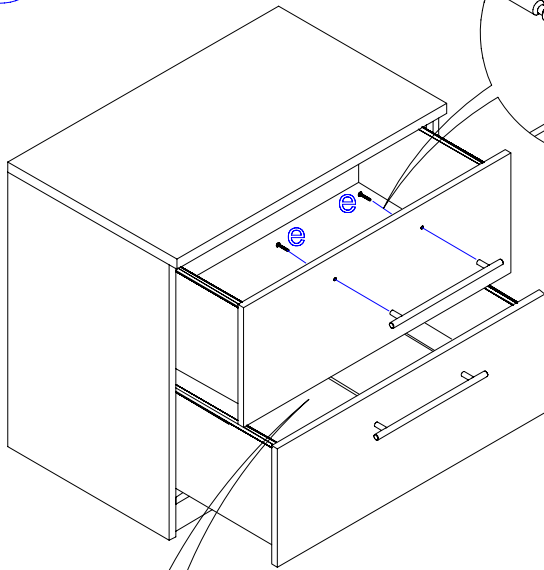

1/32/20/0

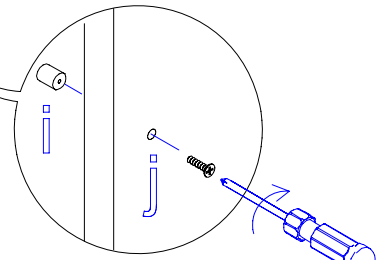
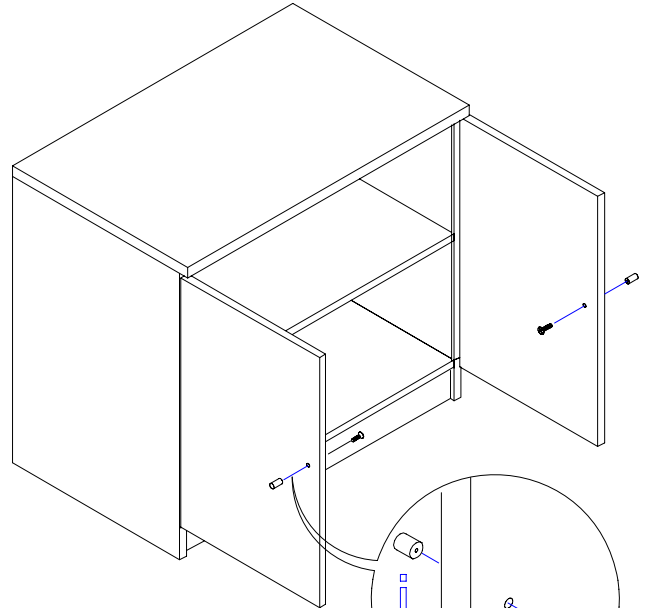

1/63/20/2

