

ASSEMBLY INSTRUCTIONS

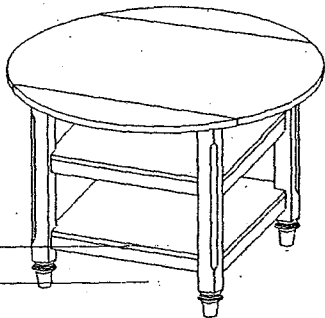









page 1

ITEM#: PD-6014(Dining table)





Cottage Table

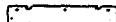

HARDWARE LIST

NO	Description	Figure	QTY
A	Plastics cover		12PCS
B	Bolt		12PCS
C	Camlock		12PCS
D	Wooden Dowel		28PCS
E	Screw		36PCS
F	Hinge		6PCS
G	Camlock Bolt		16PCS
H	Camlock		16PCS
M	Glue		1PCS
N	Allen Key		1PCS

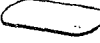
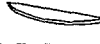
PART LIST

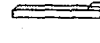
ITEM	DESCRIPTION	FIGURE	QTY
1	Top Apron		2
2	Bottom Aprons		4
3	Side frame		2
4	Top panel		1
5	Dropped table leaf		2
6	Shelf		2
7	Extension rail		4

WOODEN DOWEL INSTALLATION PROCEDURE
 APPLY GLUE TO PRE-DRILLED HOLES AND INSERT WOODEN DOWEL D AS SHOWN.

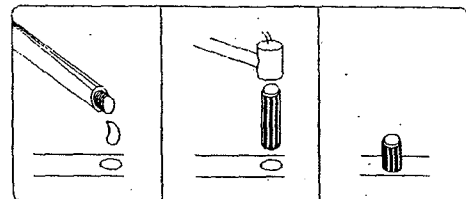

*GLUE--DO NOT PUT IN MOUTH
 *SCREWDRIVER & HAMMER NOT INCLUDED
 MADE IN CHINA

ASSEMBLY INSTRUCTIONS

ITEM#: PD-6014(Dining table)

** Select a clean, dry, scratch resistant surface before starting assembly.

** Remove all parts from box. Check to make sure all parts are present.

STEP 1

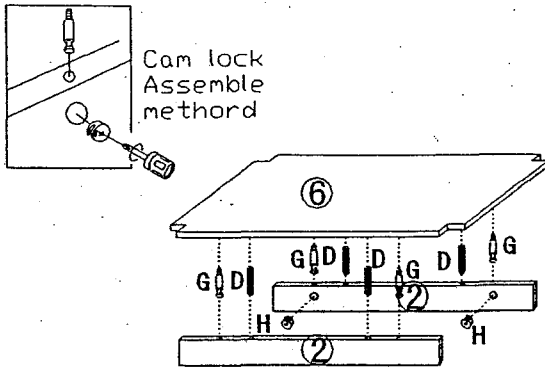

Assemble bottom Apron (2) to shelf (6) by using wooden dowel (D), camlock bolt (G) and camlock (H) as shown.

STEP 2

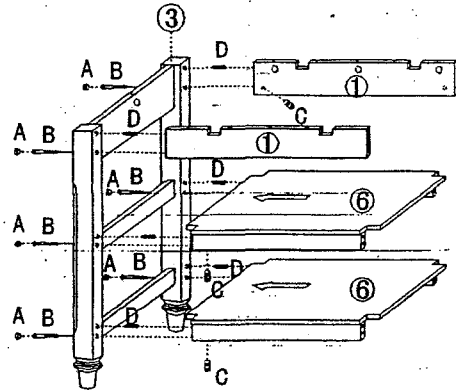

Assemble top apron (1) and step one assembled unit to side frame (3) by using camlock bolt (B), camlock (C) and wooden dowel (D) as shown. Then plug in plastics cover (A) to holes as shown.

STEP 3

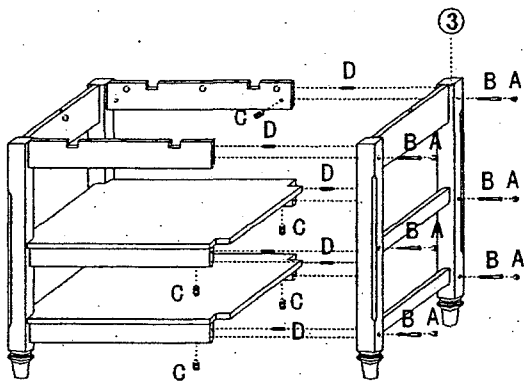

Assemble side frame (3) to step 2 assembled unit by using camlock bolt (B), camlock (C) and wooden dowel (D) as shown. Then plug in plastics cover (A) to holes as shown.

STEP 4

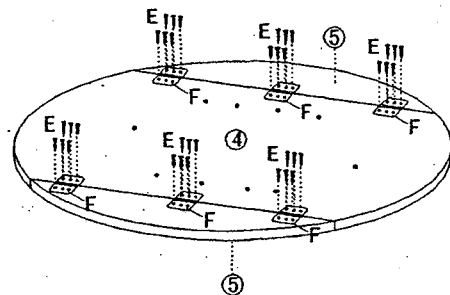

Assemble top panel (4) and dropped table leaves (5) together by using screw (E) as shown.

ASSEMBLY INSTRUCTIONS

page 3

ITEM#: PD-6014(Dining table)

** Select a clean, dry, scratch resistant surface before starting assembly.

** Remove all parts from box. Check to make sure all parts are present.

STEP 5

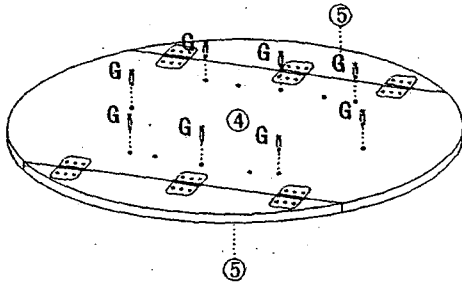

Screw camlock bolt (G) to back of table top (4) as shown.

STEP 6

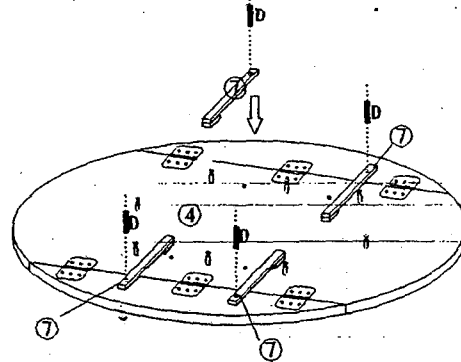

place extension rail (7) onto back of table top (4) as shown. (D) and camlock

STEP 7

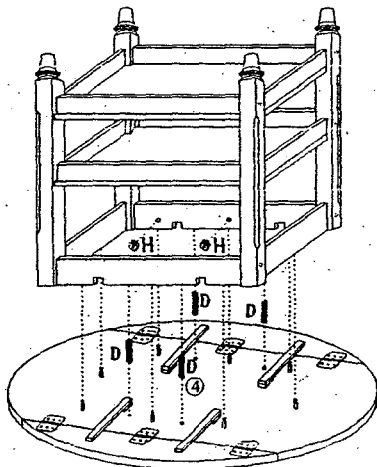

Assembled table top unit to step 3 assembled unit by using wooden dowel (D) and camlock (H) as shown.

STEP 8

