



Thank-you for purchasing a **Masonry 350F** from an Imer U.S.A. dealer. Your decision is an intelligent one.

There is no other sawing machine in the world which delivers the benefits and features of the Masonry 350F:

- Extremely rigid, mig welded bar steel frame.
- 5.5 H.P. Honda engine.
- Compact design for easy transportation.
- Extremely rigid worktable for a precise cutting.

At IMER U.S.A. we continually search for ways to better serve our customers. Should you have an idea or thought to share with us regarding this product we would appreciate hearing from you. Our motto is "Tools and Services for the 21st Century". We look forward to delivering the goods.

Thank you again for your purchase.

Mace T. Coleman, Jr.
President, Imer U.S.A, Inc.

IMERWEST
207 Lawrence Avenue
So. San Francisco, CA 94080
Tel 650 - 872 - 2200
Fax 650 - 873 - 6482

IMER EAST
221 Westhampton Place
Capitol Heights, MD 20743
Tel 301 - 336 - 3700
Fax 301 - 336 - 6681

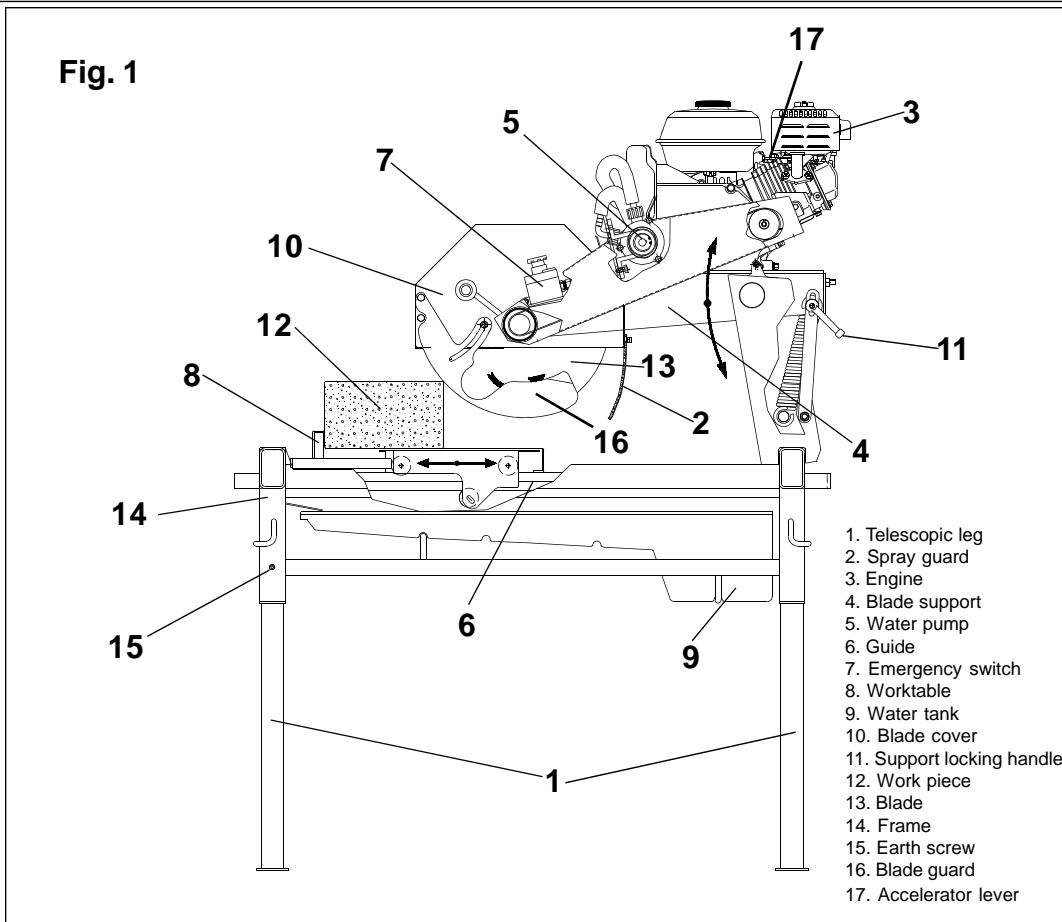



Dear Customer,

Congratulations on your choice of purchase: this IMER saw, the result of years of experience, is a fully reliable machine and is equipped with the latest technical innovations.

⚠ - WORKING IN SAFETY

Please read this manual before beginning to assemble or operate this piece of equipment.

- This OPERATION AND MAINTENANCE manual must be kept on site by the person in charge, e.g. the SITE FOREMAN, and must always be available for consultation.
- This manual is to be considered an integral part of the machine, and it must be preserved for future reference (EN292/2) throughout the machine's normal working life. If the manual is damaged or lost, a replacement may be requested from the saw manufacturer.
- The manual contains important information regarding site preparation, installation, machine use, maintenance procedures and requests for spare parts. Nevertheless, the installer and the operator must both have adequate experience and knowledge of the machine prior to use.
- To guarantee complete safety of the operator, safe operation and long life of equipment, follow the instructions in this manual carefully, and observe all safety standards currently in force for the prevention of accidents at work. Use personal protection (safety footwear, suitable clothing, gloves, goggles, etc.).

⚠ - Safety glasses or a protective visor must be worn at all times.

⚠ - Ear protection must be worn at all times.

⚠ - MAKE SURE THAT WARNING SIGNS ARE ALWAYS LEGIBLE.

⚠ - It is strictly forbidden to carry out any form of modification to the steel structure or working parts of the machine.

IMER INTERNATIONAL declines all responsibility for non-compliance with laws and standards governing the use of this equipment, in particular; improper use, defective power supply, lack of maintenance, unauthorised modifications, and partial or total failure to observe the instructions contained in this manual.

IMER INTERNATIONAL is entitled to modify the characteristics of the sawing machine and/or the contents of this manual without necessarily updating previous machines and/or manuals.

1. TECHNICAL DATA

Table 1 shows the saw's technical data, referring to figure 1.

TABLE 1 - TECHNICAL DATA		
Blade rpm	rpm	2.450
Blade diameter	in.	14"
Blade mounting hole	in.	1"
Engine type		Honda GX 160
Power engine	Hp	5.5 / 3.600 rpm
Motor rpm	rpm	3.400
Cutting table dimension	in.	20" x 17"
Overall dimensions (widthxlengthxheight)	in.	34" x 47" x 58"
Overall dimensions for transport (widthxlengthxheight)	in.	33" x 50" x 46"
Weight	lb.	250
Weight for transport	lb.	300
Blade rotation direction(seen from blade clamping flange)	CLOCK WISE	

2. DESIGN STANDARDS

MASONRY 350 F saws are designed and manufactured according to the following standards: EN 292-1-2; EN 12418.

3. NOISE EMISSION LEVEL

Table 2 indicates the environmental noise levels measured for the panel saw (lwa) in accordance with EN ISO 3744 and the acoustic pressure level measured at the operator's ear with the machine empty (Lpa).

TABLE 2 - [dB(A)]			
SAWING MACHINE	TYPE OF MOTOR	L _{PA}	L _{WA}
Masonry 350F ENG	HONDA GX 160 K1(Hp 5.5)	95	107

4. CUTTING SPECIFICATIONS

This saw model has been specially designed for cutting stone, ceramics, marble, granite, concrete and similar materials. Only water-cooled diamond blades with continuous or segmented edges (see paragraph 13) must be used. Under no circumstances must dry cutting blades be used or materials other than those specified above. IMER INTERNATIONAL declines all responsibility for damage caused by improper use of the above machine.

5. CUTTING CAPACITY

- max. cutting capacity with vertical blade = 5 " in. one single pass.
- max. height of workpiece: 9" in. in two passes.
- min. width of workpiece: 2" in.
- max. cutting length: 18" in. (with blade lowered), 21" in (with blade fully raised).
- Blade at 45°: with support at 45° on the work surface.

6. WARNING

- Do not load the saw with workpieces that exceed the specified weight (max. 90 lb.)
- Ensure stability of machine: it must be installed on a solid base with a maximum slope of 5° (fig. 2).
- Ensure the workpiece is stable before, during and after cutting: in any case, workpieces must not overhang the worktable.
- Respect the environment; use suitable receptacles for collection of cooling water contaminated with cutting dust.

7. SAFETY PRECAUTIONS

IMER saws are designed for work on construction sites and under conditions of natural light, hence the workplace must be adequately lit.

⚠ - The machine must never be used in environments subject to risks of explosion and/or underground sites



Fig. 3

IMER saws may only be used when fitted with all required safety devices, which must be in perfect condition.

The symbol shown on the label (fig. 3) indicates the warning "ENSURE ALL PROTECTION DEVICES ARE INSTALLED AND IN PERFECT CONDITION BEFORE SWITCHING ON THE MACHINE".

8. TRANSPORTATION (fig.4)

⚠ - WARNING Lock blade support arm by means of the relative handle before moving the saw (ref. 11, fig. 1). To transport the machine use slinging equipment with 4 rope legs, fixing the hooks to the relative attachments (fig. 4).

9. INSTALLATION (fig. 4)

- Lift the machine out of its package using slinging equipment with 4 rope legs. Fix the hooks to the relative attachments.
 - Unlock the legs by sliding out the split pins (ref.1).
 - Lock the legs at working height. Refit the pins in the leg supports and insert the split pins.
 - Install the machine on a completely even and stable surface.
 - Release the carriage from the lever that secures it to the frame.
 - Fill the pump with water, unscrewing the connector (fig.10).
- When installing on site it is good practice to connect the machine's metal structure to the earthing system by means of the screw (fig.1 ref.15) using an earthing braid (or cable) with a minimum cross-section of 16 mm².

10. STARTING THE MACHINE.

The endothermic motor is equipped with a centrifugal clutch which engages automatically, transmitting drive to the cutting wheel as the engine revs up.

The hazard warnings and the instructions for use and maintenance contained in the manual enclosed with the endothermic engine must be read and understood before the engine is started.

- 1-Check the engine (see enclosed engine manual).
- 2-Check the oil level in the motor; horizontal motor position (see enclosed motor manual).
- 3-Fill the fuel tank (enclosed engine manual).
- 4-Set the accelerator lever to minimum, so as to start the motor without turning the cutting wheel (clutch not engaged).
- 5-Warm the engine by letting it run at low speed

⚠ - Emergency-stop: press the engine stop button (ref. 7, fig. 1), (turn to switch on again).

Keep far enough away from the saw when it is running to avoid inhaling exhaust gases from the endothermic engine.



- Turn off the engine before topping up the tank with petrol.

Saws with endothermic engines must be used in the open air. If they have to be used in closed environments, the openings must be provided to conduct gases from the engine's exhaust pipe to the outside using appropriate non-flammable flexible tubes.

These must be checked for leaks and breakages at the beginning of every shift.

- Do not start the machine with the blade in the workpiece.

When the saw is not being used, turn the petrol cock to the OFF position.

10.1 STARTING ROTATION OF THE CUTTING WHEEL.

Gradually move the lever (ref.17; fig.1) so as to bring the motor revs up to normal working speed and start the wheel turning at the cutting speed foreseen.

11. STARTING THE MACHINE

Before cutting:

- 1 - Check that there is enough cooling water in the tank.
- 2 - adjust the flow of cooling water by turning the cock next to the blade guard (do not perform cutting without water).
- 3 - Ensure that blade rotation corresponds to the indications on the blade guard.
- 4 - If everything is in order, work can begin.

12. EMERGENCY - STOP

- In an emergency, stop the machine by pressing the stop control switch (ref. 7, fig. 1).

13. BLADE INSTALLATION (Fig.5)

By means of a hex wrench no.10, unscrew the 3 screws that lock the moving blade guard (ref.3). Use a hex wrench no. 13 to remove the screw that locks the flanges on the disc: **this screw has a left-hand thread** (rif.1). Remove the mobile flange (rif.2) and check that the flanges, disc shaft and blade are not damaged.

- Never use worn blades or blades with missing segments.

- Only use blades that are designed for the number of revolutions indicated on the machine rating plate.

- Check that blade rotation corresponds to that indicated on the blade guard.

Centre the blade against the fixed flange, position the mobile flange and tighten the securing screw by means of a hex wrench no. 13 (turn clockwise). Refit the moving blade guard, tightening the 3 screws (ref.3).

- Ensure that the blade guard (ref.3) is locked securely into position.

- **WARNING!** An incorrectly installed blade, or a screw insufficiently tightened can provoke damage to the machine or injury to persons.

- Note that the blade must have an external diameter of 14" in. , a central hole diameter of 1" in. and max. thickness of 1/8" in..

- Check that the blade to be used is suitable for the material to be cut.

- Do not use blades for wood! (fig. 6).



Fig. 6

14. USE

- Leave a space of at least 5 ft. around the machine to operate in full safety.

- Do not allow other persons to approach the machine during cutting.

- Never use the machine in fire-risk areas. Sparks can cause fire or explosions.

- Make sure that the machine is switched off before positioning or handling.

- Always ensure that the blade is free of any contact before start-up.

- Ensure correct installation of all protective devices.

- Before starting work, fill the water tank. Top up during operation whenever necessary: N.B. the pump suction hose must always remain immersed in water.

- **WARNING!** For safety purposes the removal of protective guards from the machine is strictly prohibited.

- **WARNING!** Always switch off the machine before carrying out blade adjustment.

Loading and unloading pieces on the machine cutting table.

To avoid the risk of accidental contact with the cutting wheel, the pieces must be positioned and removed from the carriage with the cutting wheel stopped. This is done by adjusting the lever (ref.17;fig.1) so as to reduce the revs to minimum, thus disengaging the clutch.

14.1 VERTICAL BLADE MOVEMENT

To raise or lower the blade, slacken the support locking handle turning it anti-clockwise (ref. 11, fig. 1). The blade support remains free to rotate, so it can be secured in the desired position, fully tightening the handle (ref. 11, fig. 1).

- Ensure that the locking handle is tightened fully before starting work.

14.2 BLADE POSITIONING FOR 45° CUTS

To make a cut at 45° the 45° support on the carriage is necessary. Once the workpiece is correctly positioned, cutting can begin, starting the endothermic engine.

14.3 CUTTING

For safe use of the machine when cutting, push the carriage forwards as the cut advances, placing your hands to the two sides of the carriage. Never push directly on the piece to be cut.

- Check that the blade is aligned with the cutting line.

- Place the workpiece on the worktable (ref. 8, fig. 1), resting firmly against the stop.

- Start the engine.

- Wait until the water reaches the blade.

- Begin cutting.

- Horizontal cutting movement is carried out by pulling the carriage towards the blade.

- As cutting thickness increases, the blade is subjected to greater stress. To avoid overloading the engine, the operator should continually check blade feed speed. The speed will also depend on the characteristics of the material being cut (hardness, toughness etc.).

14.3.1 CUTS WITH BLADE LOWERED FROM ABOVE

Bring the blade support to its highest position and lock. Position the workpiece on the worktable. Start the machine and begin vertical cutting until the blade reaches its lowest point. Lock the support locking handle and proceed with horizontal cutting

14.3.2 BLADE CHANGE

To change the blade refer to section 13.

15. MAINTENANCE

- **WARNING!** Servicing must always be carried out by skilled personnel and only after the endothermic engine has been turned off.

- Always keep the guards in proper working order and free from damage. Take particular care to ensure that the blade guards are kept efficient and clean, replacing them if they are damaged.

- **WARNING!** Recommended product for cleaning mechanical parts: WD-40.

Do not leave the machine outside: it must always be protected from the weather.

Below is a list of the cleaning operations that must be carried out at the end of every shift.

15.1 TANK CLEANING

Empty the tank by removing the drain plug. Remove cutting residue using a jet of water.



15.2 TANK REMOVAL (Ref.Fig.7).

- Lift the tank (ref.1) to detach it from its supports (ref.2) and remove it from the side indicated by the arrow.

15.3 WORK SURFACE CLEANING

Always keep work surfaces clean. Residual dirt can impair cutting precision.

15.4 GUIDE RAIL CLEANING

It is good practice to remove all traces of dirt from the guides.

15.5 CLEANING AND MAINTENANCE OF COOLING CIRCUIT

- If water does not reach the blade stop the machine immediately to avoid blade damage.

- After switching off the machine ensure that the water level is sufficient.

- Check that there is water in the pump by unscrewing the connector, and if necessary top up until water flows out (fig.10).

 - **WARNING. Before starting the panel saw for the first time, or when starting it after long periods of inactivity, fill the pump with water as described above.**

- At the end of every shift, unscrew the suction hose filter and clean it. Then, circulate some water through it placing inside a bucket of clean water.

15.6 TENSIONING THE DRIVE BELT (fig. 8)

- Turn off the endothermic engine.

- Unscrew the 4 screws that lock the movable belt guard (ref. 1).

- Loosen the two screws (ref. 2) that clamp the water pump to the bracket and move the pulley away so that it does not touch it.

- Loosen the 4 screws (ref. 3) that clamp the endothermic engine to the blade support.

- Tension the belt using the nut (ref. 4): apply a force of about F=14 lb. to the centre of the free section of the belt, the arrow should be about f=1/4" in. (fig. 9).

- Tighten the screws on the endothermic engine, checking the alignment of the engine pulley and the blade pulley

- Lower the water pump until the pulley touches the drive belt. Tighten the two screws.

- Refit the guard and lock it using the 4 screws.

 - **To avoid shortening the life of the belt, the bearings and the blade shaft, do not overtension the belt. Finally, check the two pulleys are aligned.**

15.7 DRIVE BELT REPLACEMENT

Repeat the operations described in section 15.6, replacing the belt before tensioning it.

15.8 ENDOTHERMIC ENGINE MAINTENANCE

Read the Honda manual carefully... and follow their instructions. Changing the oil (with the engine in horizontal position) and cleaning the air filter frequently ensure a reliable and long lasting engine.

When you may need Honda Engine Service or Warranty Assistance take the machine to your local Honda power equipment dealer, they will honour the Warranty throughout America.

 - **It is always a good idea to check the oil level in the engine crankedcase at the start of each working day. Clean oil at the correct level marks for an engine that will last and last.**

15.9 REPAIRS

 - **Do not start the saw during repair work.**

Only use genuine IMER spare parts and do not modify them.

 - **If the guards are removed to carry out repairs, they must be refitted properly when the repair work is finished.**

16. TROUBLESHOOTING

 - **WARNING. Stop the saw and turn off the endothermic engine before carrying out any maintenance.**

FAULT	CAUSE	REMEDY
Vertical blade movement not smooth	- locking knob too tight	- Slacken knob
Horizontal carriage movement not smooth	- Guide rails dirty	- Clean the guide rails
Lack of cooling water supply to blade	Refer to section 15.5: "cleaning and maintenance of cooling circuit" (Chapter 15.5)	
Blade does not cut	- Blade is worn	- Fit newblade
	- Drive belt not tensioned	- Tension the belt
Motor starts but blade does not rotate	Belt is broken	Replace drive belt

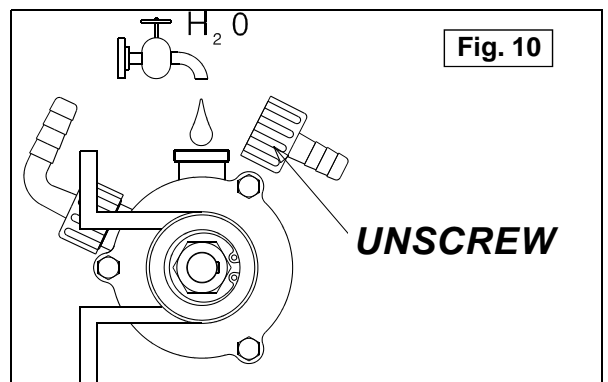
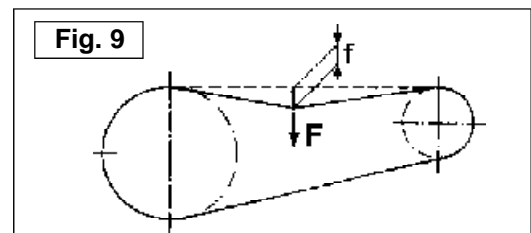
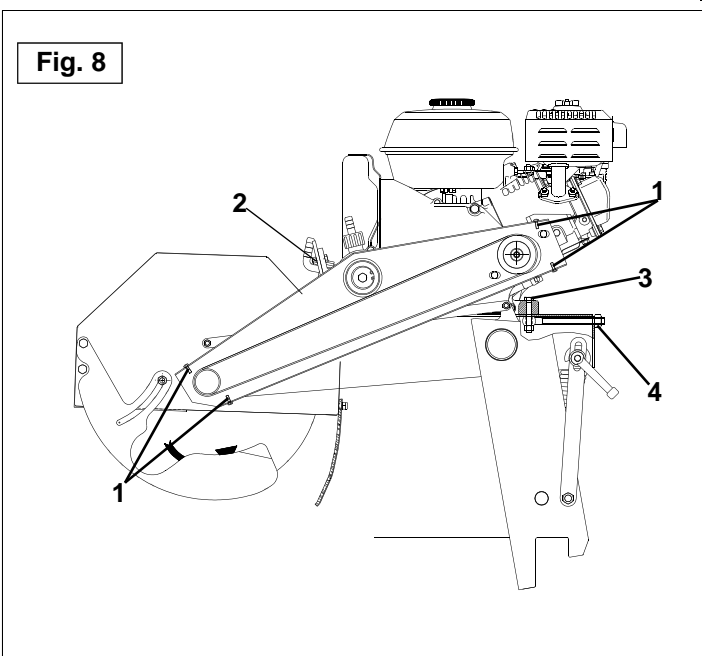
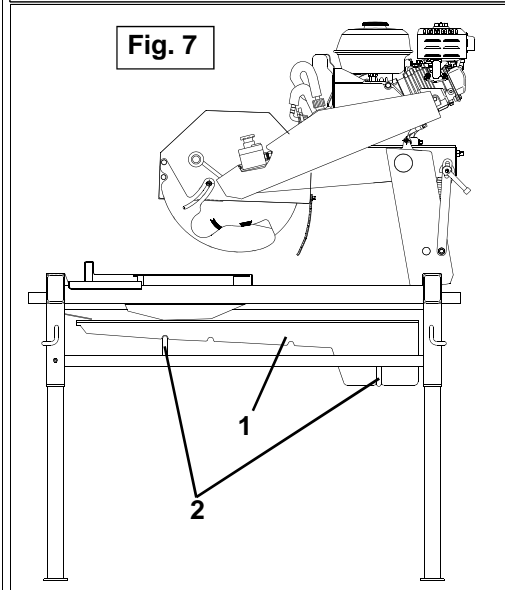
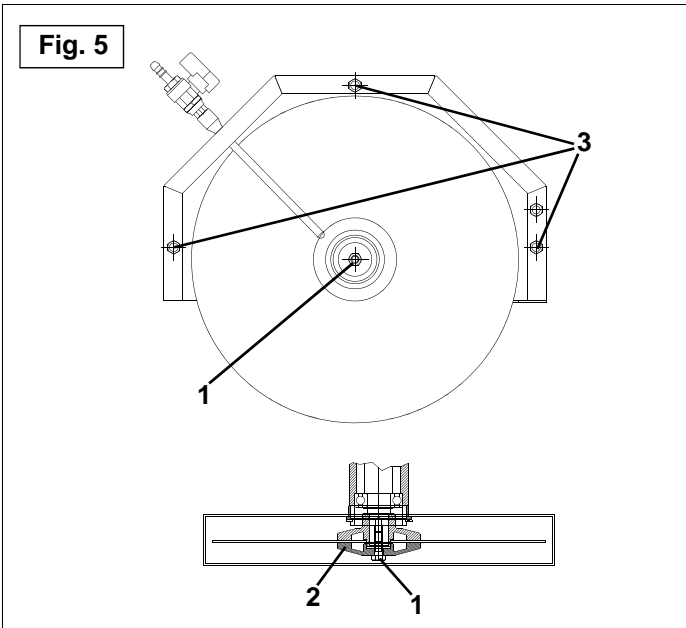
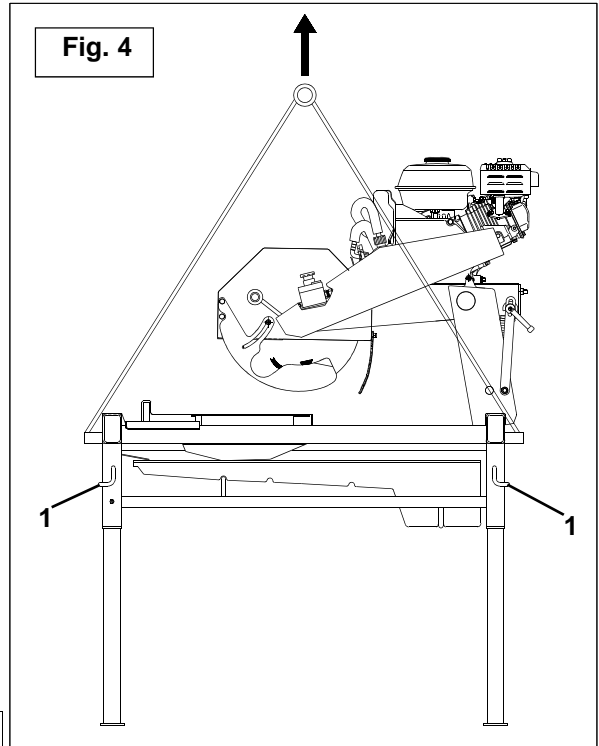
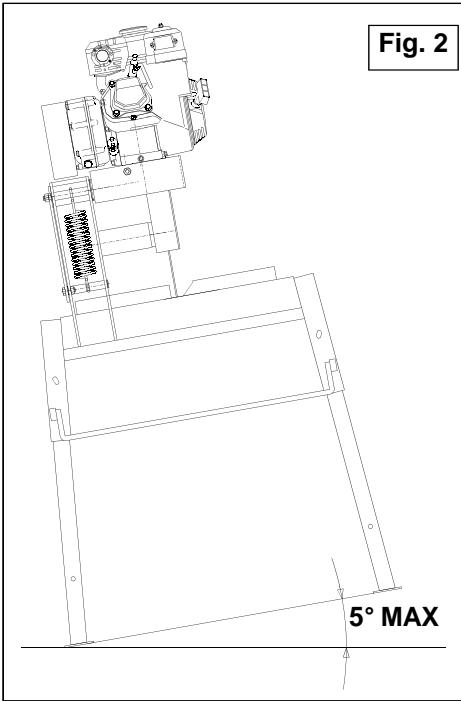

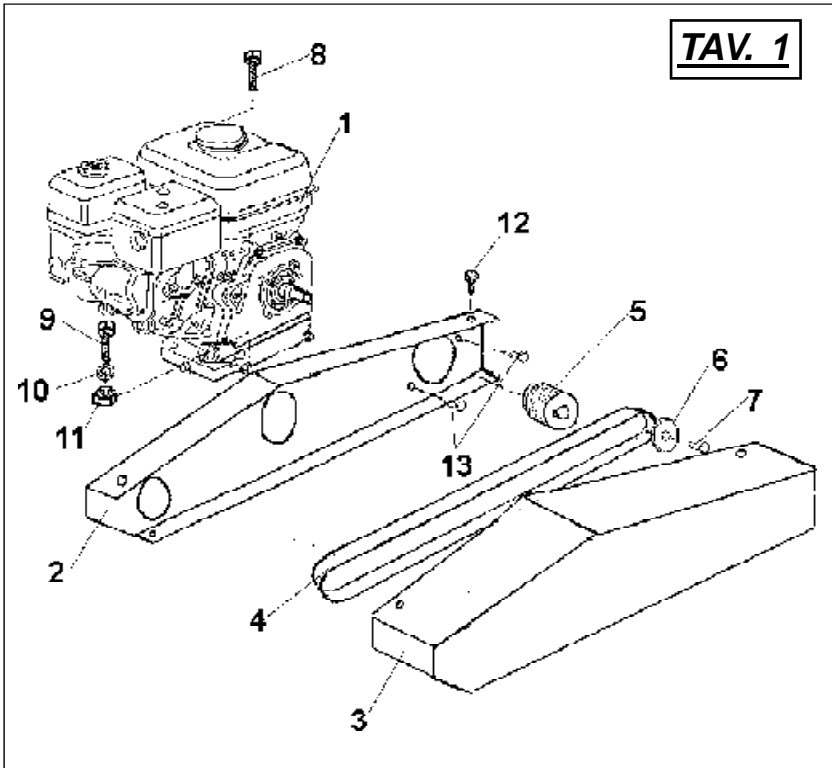

TAV. 1

TAV.1 - ASSEMBLY OF MOTOR			
RIF.	COD.	GB	NOTE
1	3210291	MOTOR	HONDA GX 160
2	3210139	BELTS INTERNAL COVER	
3	3210148	BELTS EXTERNAL COVER	
4	3210185	BELT	
5	3210159	PULLEY	
6	2224190	WASHER	8X32 Z
7	2222076	BOLT	M8X25 Z
8	2222176	BOLT	M8X50 Z
9	2222004	BOLT	M8X35 Z
10	2224140	WASHER	8X18 Z
11	2223923	SELF LOCKING NUT	M8 Z
12	3203921	BOLT	M5X10 Z
13	2222021	BOLT	M6X16 Z

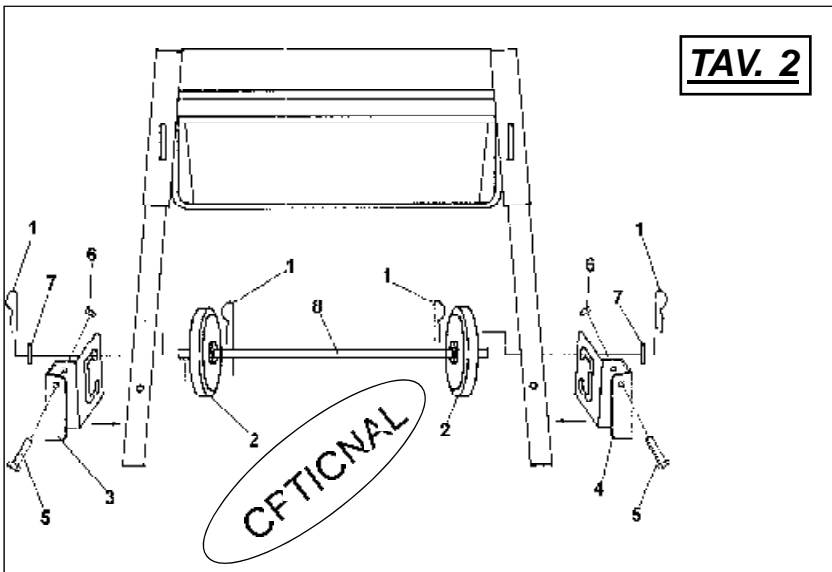

TAV. 2

TAV.2 - WHEEL KIT			
Rif.	Cod.	GB	Note
1	2226700	SPLIT PIN	
2	2211150	WHEEL	
3	3206261	LEFT TUBE GUIDE	
4	3206262	RIGHT TUBE GUIDE	
5	2222082	SCREW	5739 M 10X60 Z
6	2223650	DISK	5588 M10 Z
7	3206641	WASHER	6592 28X50X2 Z
8	3206260	WHEEL TUBE	

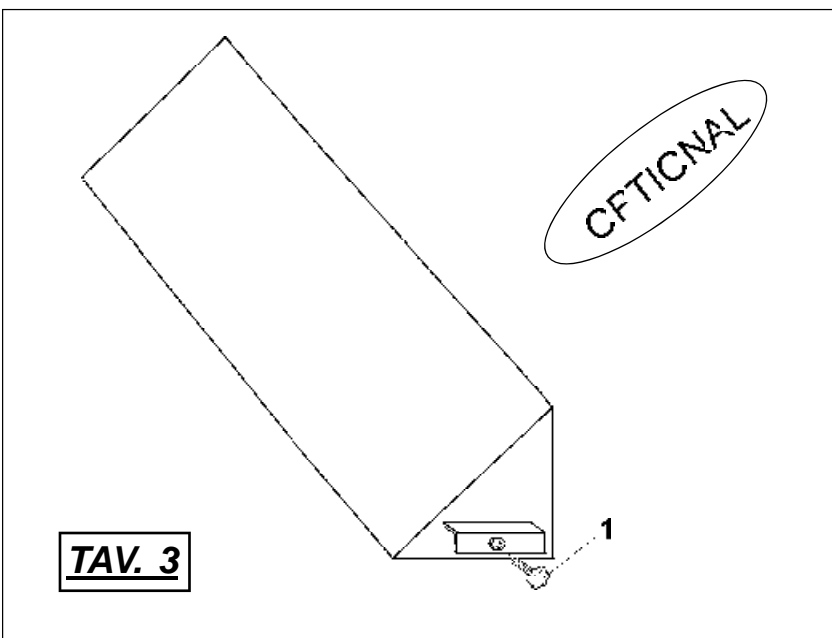

TAV. 3

TAV.2 - 45° SUPPORT			
Rif.	Cod.	GB	Note
1	2284859	KNOB	



TAV. 4

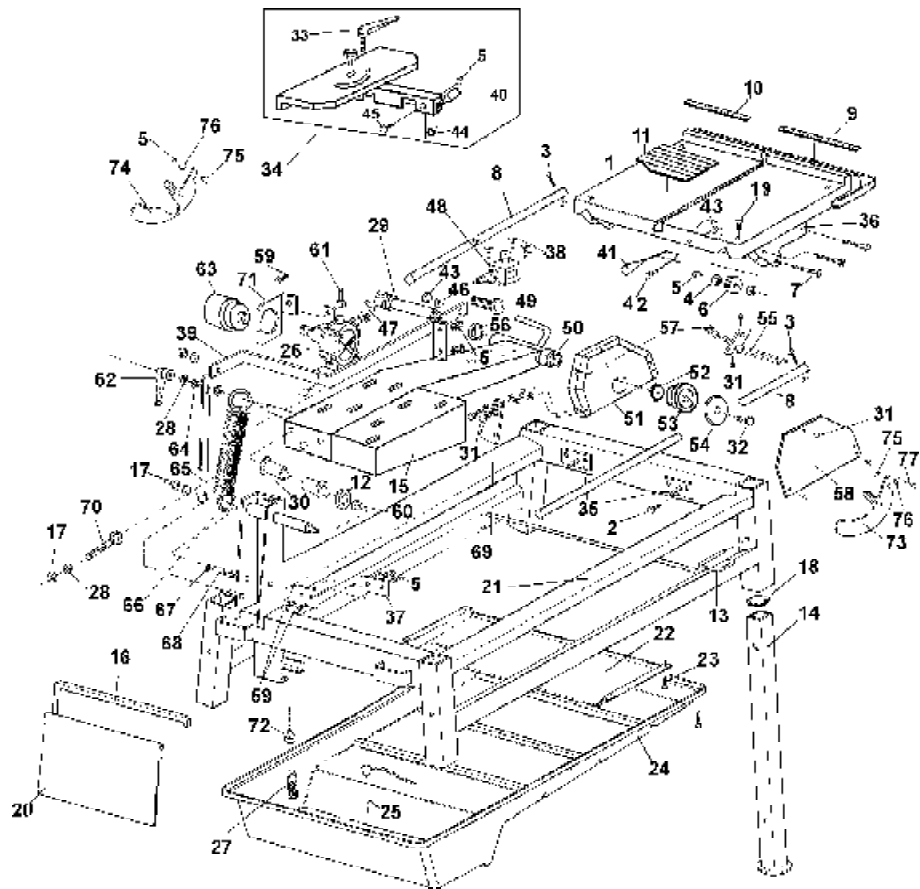

TAV. 4 - MACHINE STRUCTURE

RIF.	COD.	GB	NOTE
1	3208421	CARRIAGE	
2	2222061	BOLT	5739 M 8X20 Z
3	2222515	BOLT	5931 M 8X16 Z
4	3204945	BEARING	608-2RS1
5	2223923	SELF LOCKING NUT	M 8 Z
6	3207397	WHEEL	
7	2222090	BOLT	5737 M 8x75 Z
8	3210193	GUIDE BAR	
9	3208442	LEFT FENCE ADHESIVE LABEL	
10	3208441	RIGHT FENCE ADHESIVE LABEL	
11	3205581	RUBBER COATING	
12	2224612	WASHER	D.21X43 Z
13	3206086	PIN	
14	3201517	LEG	
15	3210178	CUTTING HEAD GROUP	
16	3206096	SUPPORT	
17	2223920	SELF LOCKING NUT	M 10 Z
18	3201015	PLUG	
19	2222587	SCREW	5933 M 8X20 Z
20	3210171	SPRAY GUARD	
21	3210169	FRAME	
22	3205526	WATER RUN-OFF TRAY	
23	2222425	SCREW	AUTOFOR.TE 4,2X13
24	3204818	DRUM	
25	2235428	PLUG	
26	3210173	WATER PUMP	
27	3210183	WATER FILTER	
28	2224320	WASHER	D.10X21X2
29	3210158	SHAFT	
30	2209450	NYLON BUSHING	
31	2222002	SCREW	5739 M 6x16 Z
32	2222059	SCREW	5739 M8X25 Z SX.
33	3208414	LEVER	
34	3208422	GONIOMETER	
35	3207213	GUIDE BAR SUPPORT	
36	3208428	TROLLEY SLIDE	
37	3210236	GUIDE BAR SUPPORT SX	
38	2222580	SCREW	M 4X20 Z

TAV. 4 - MACHINE STRUCTURE

RIF.	COD.	GB	NOTE
39	3210153	ROTATION ADJUSTING ROD	
40	3209333	KNOB	M 8 Z
41	3210297	TROLLEY CLAMPING	
42	2222016	SCREW	5739 M 6x20 Z
43	2223924	NUT	M 6 Z
44	3209332	CAM	
45	2222018	SCREW	5931 M 8X35 Z
46	2224534	WASHER	6X12.5 Z
47	3210416	HOOSE JOINT 90° 1/4"	
48	3210175	EMERGENCY SWITCH	
49	2288885	HANDGRIP	
50	3206513	BEARING	6205 2RS
51	3210179	DISC COVER	
52	3232759	OIL SEAL RING	35X52X7
53	3204777	INNER FLANGE	
54	3204776	OUTER FLANGE	
55	3210156	WATER HOSE	
56	3210629	BEARING	6006 2RS
57	3205635	VALVE	
58	3210140	BLADE COVER	
59	2222006	SCREW	M 8X30 Z
60	3210189	SELF LOCKING NUT	M 20 Z
61	3210418	HOOSE JOINT 1/4"	
62	3204889	LEVER	
63	3210160	PULLEY	
64	2224910	WASHER	DEV. D.10 Z
65	3210142	BLADE GUARD ROTATION ROD	
66	3210152	SPRING	
67	2227320	STOP RING	E/20
68	3210181	SPRING PIN	
69	3210206	SPRAY GUARD	
70	3210149	TIE ROD SCREW	
71	3210229	PUMP COVER SHEET	
72	2226778	HOOSE JOINT F3/8	
73	3210542	DISK PROTECTION DX	
74	3210543	DISK PROTECTION SX	
75	3210576	NYLON WASHER	8.4XX17X1.5
76	2224140	WASHER	8X18 Z.
77	2222110	SCREW	8X80 Z

ONE YEAR WARRANTY

We warrant to the original purchaser that the IMER equipment described herein (the "equipment") shall be free from defects in material and workmanship under normal use and service for which it was intended for a period of one (1) year from the date of purchase by the original purchaser.

Our obligation under this warranty is expressly limited to replacing or repairing, free of charge, F.O.B. our designated service facility, such part or parts of the equipment as our inspection shall disclose to be defective. Parts such as engines, motors, pumps, valves, electric motors, etc. furnished by us but not manufactured by us will carry only the warranty of the manufacturer. Transportation charges or duties shall be borne by the purchaser. This shall be the limit of our liability with respect to the quality of the equipment.

This warranty shall not apply to any equipment, or parts thereof, which has been damaged by reason of accident, negligence, unreasonable use, faulty repairs, or which has not been maintained and operated in accordance with our printed instructions for our equipment. Further, this warranty is void if the equipment, or any of its components, is altered or modified in any way.

THIS WARRANTY IS EXPRESSLY IN LIEU OF ALL OTHER WARRANTIES, EXPRESSED OR IMPLIED, INCLUDING ANY IMPLIED WARRANTY OF MERCHANTABILITY OF FITNESS FOR A PARTICULAR PURPOSE.

We make no other warranty, representation or guarantee, nor is anyone authorized to make one on our behalf. We shall not be liable for any consequential damage of any kind, including loss or damage resulting, directly or indirectly, from the use or loss of use of the machine. Without limiting the generality of the foregoing, this exclusion from liability embraces the purchase's expenses for downtime, damages for which the purchaser may be liable to other persons, damages to property, and injury or death of any persons.

This warranty shall not be deemed to cover maintenance parts, including but not limited to blades, belts, hoses, hydraulic oil or filters, for which we shall have no responsibility or liability whatsoever.

IMER U.S.A., Inc.
207 Lawrence Avenue
South San Francisco, California 94080
(650) 872-2200