

EC6582/EC6583 HIGH BACK ECO LEATHER CHAIR ASSEMBLY INSTRUCTIONS

STEP 1

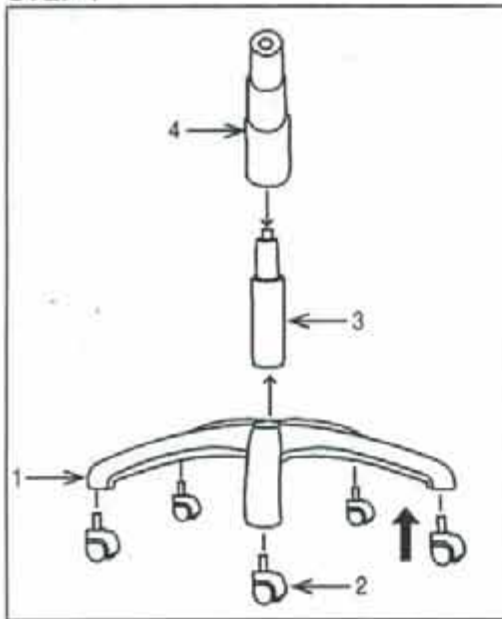

STEP 2

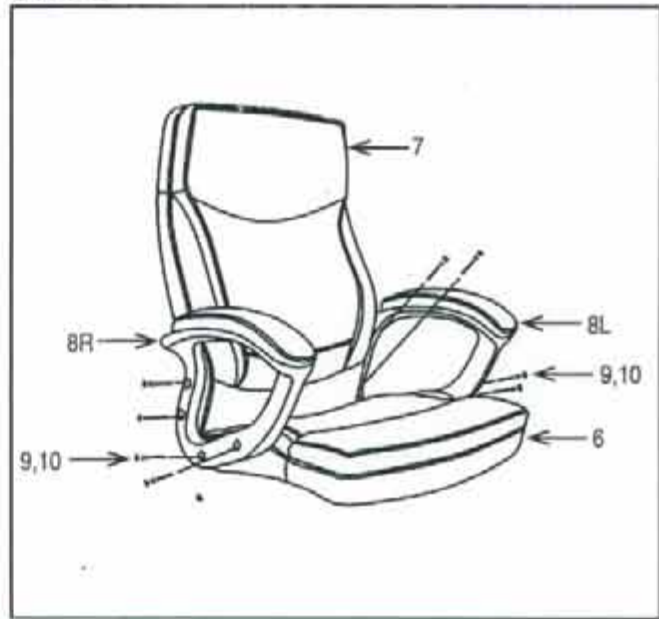

STEP 3

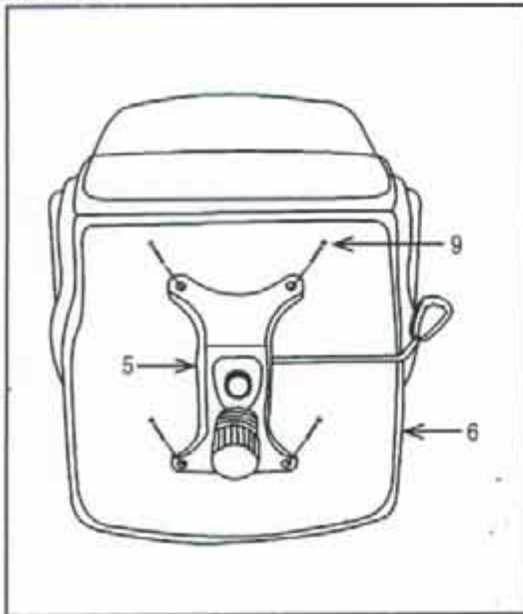

STEP 4



PART	QTY
1. Base	1
2. Casters	5
3. Pneumatic Cylinder	1
4. Bellows	1
5. Seat Plate	1
6. Seat Cushion	1
7. Back Cushion	1
8. Arms (8L & 8R)	2
9. Screws	12
10. Plastic Caps	8
11. Allen Wrench (not shown)	1

Remove all parts from carton, separate by part numbers indicated on parts list, and verify part quantities.

STEP 1 Insert five Casters (2) into Base (1), push hard until you feel or hear the Caster (2) snap into place. Insert Pneumatic Cylinder (3) into Base (1) and slip Bellows (4) over Pneumatic Cylinder (3).

STEP 2 Align holes of Arms (8L & 8R) with holes of Seat Cushion (6) and Back Cushion (7), secure Arms (8L & 8R) using four Screws (9) for each Arm, **FULLY TIGHTEN ALL SCREWS**. Cover holes in Arms (8) using eight Plastic Caps (10).

STEP 3 Attach Seat Plate (5) to Seat Cushion (6) with the arrow towards the front of the chair, using four Screws (9), **FULLY TIGHTEN ALL SCREWS**.

STEP 4 Place the assembled seat on top of Pneumatic Cylinder (3) and apply downward pressure.

ATTENTION: MAKE SURE ALL SCREWS ARE FULLY TIGHTENED BEFORE USING CHAIR.

EC6582/EC6583 HIGH BACK ECO LEATHER CHAIR ASSEMBLY INSTRUCTIONS

STEP 1

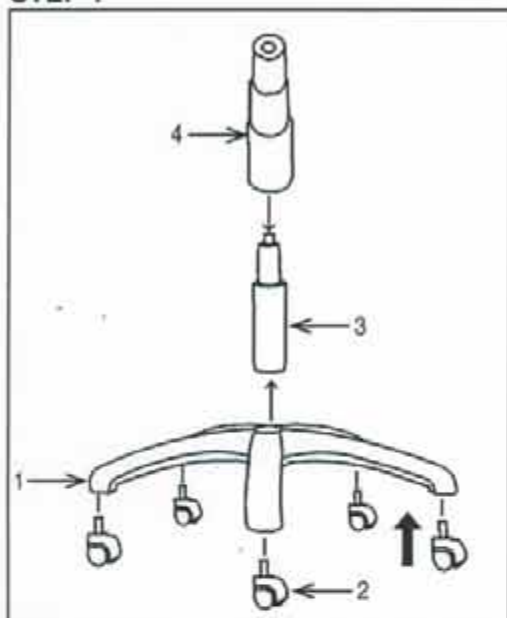

STEP 2

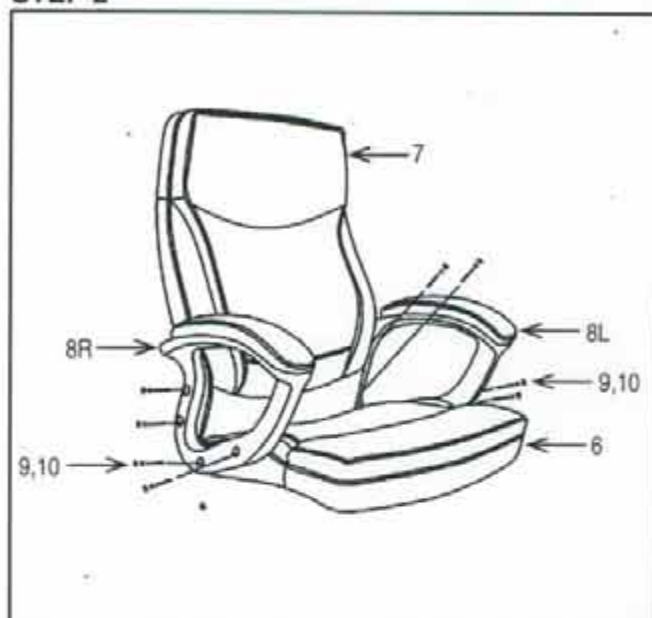

STEP 3

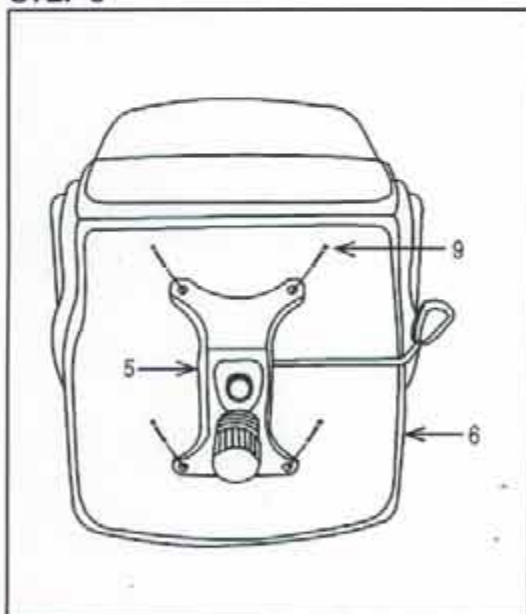

STEP 4



PART	QTY
1. Base	1
2. Casters	5
3. Pneumatic Cylinder	1
4. Bellows	1
5. Seat Plate	1
6. Seat Cushion	1
7. Back Cushion	1
8. Arms (8L & 8R)	2
9. Screws	12
10. Plastic Caps	8
11. Allen Wrench (not shown)	1

Remove all parts from carton, separate by part numbers indicated on parts list, and verify part quantities.

STEP 1 Insert five Casters (2) into Base (1), push hard until you feel or hear the Caster (2) snap into place. Insert Pneumatic Cylinder (3) into Base (1) and slip Bellows (4) over Pneumatic Cylinder (3).

STEP 2 Align holes of Arms (8L & 8R) with holes of Seat Cushion (6) and Back Cushion (7), secure Arms (8L & 8R) using four Screws (9) for each Arm, **FULLY TIGHTEN ALL SCREWS**. Cover holes in Arms (8) using eight Plastic Caps (10).

STEP 3 Attach Seat Plate (5) to Seat Cushion (6) with the arrow towards the front of the chair, using four Screws (9), **FULLY TIGHTEN ALL SCREWS**.

STEP 4 Place the assembled seat on top of Pneumatic Cylinder (3) and apply downward pressure.

ATTENTION: MAKE SURE ALL SCREWS ARE FULLY TIGHTENED BEFORE USING CHAIR.