

Model 310-F / 310-FA Multi-Use Stack Chair with Fabric Seat & Back

Parts Listing

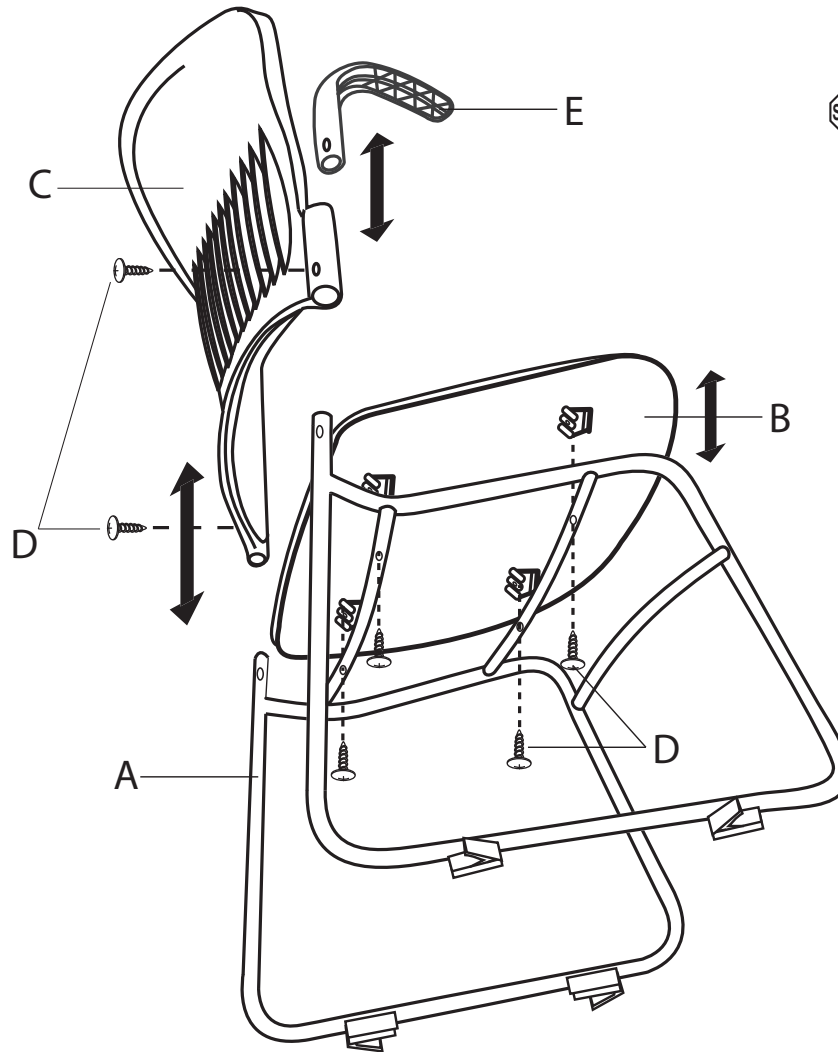
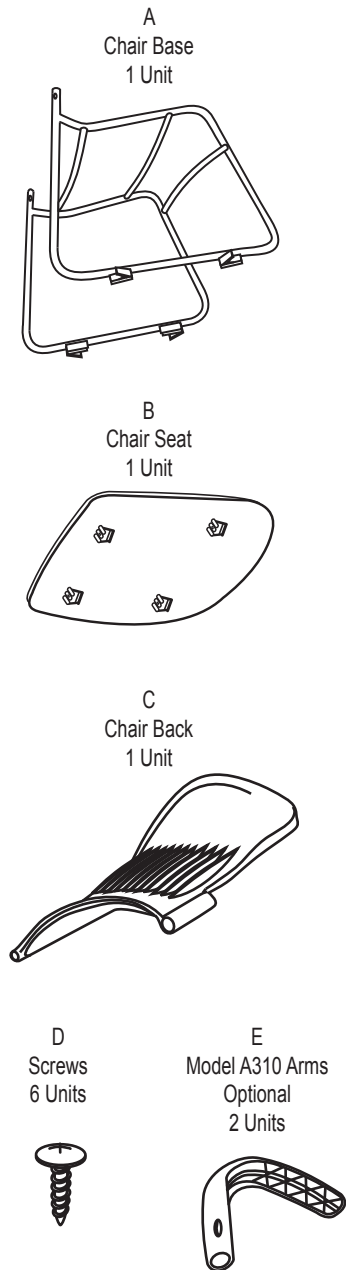

WEIGHT CAPACITY: 250 lbs.

Assembly Notes:

During assembly, hand tighten screw only when all screws are in place, you may then tighten all screws completely.

CAUTION:

1. Do not use this chair as a step ladder.
2. Check for loose screws and tighten them every 6 months.

Assembly Instructions



Tools Needed: Phillips Head Screwdriver
Please read all instructions before assembly.

Step 1: Place Chair Seat (B) onto Chair Base (A), and align screwholes. Insert Screws (D) to secure. Tighten with a screwdriver.

Step 2: Slide Chair Back (C) onto posts of Chair Base (A). Align holes and insert Screws (D) to secure. Tighten with a screwdriver

With Optional Arms (E):

Step 1: See Step 1 above.

Step 2: Slide Chair Back (C) onto posts of Chair Base (A).

Step 3: Slide A310 Arms (E) onto sides of Chair Back (C).

Step 4: Align holes in arms, back and base and insert Screws (D) to secure. Tighten with a screwdriver.

Note:

Once Model A310 Arms are added chair is no longer able to stack.

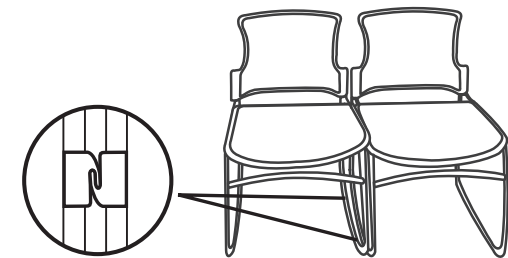

Ganging Brackets are standard on all Model 310-F/310-P/310-VAM Chairs

ofm_U
Furniture For The Real Office™

161 Tradition Trail Holly Springs, NC, 27540
800-520-7471 (voice) 919-362-4765 (fax)
919-303-6389 (voice) www.ofminc.com
support@ofminc.com