

Installation Instructions

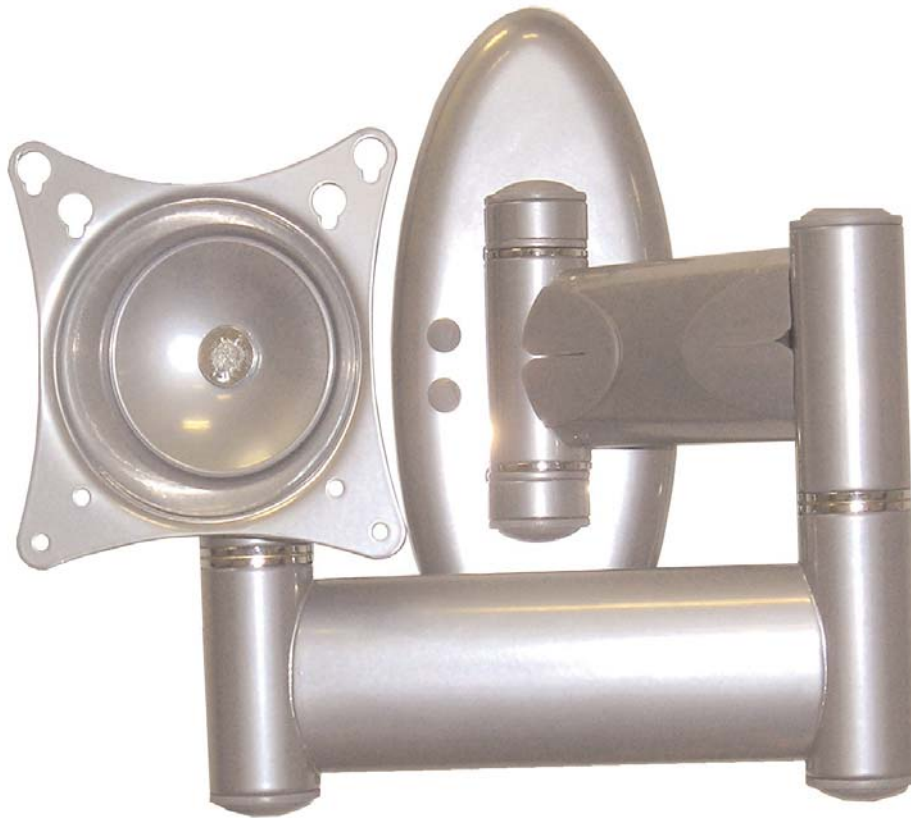

AM2/AM2-B Articulating Swingout Arm

NORTH AMERICA

3130 E. Miraloma Ave.
Anaheim, CA 92806 USA
USA and Canada -
Phone: 800-368-9700
Fax: 800-832-4888
www.mounts.com

EUROPE

Swallow House,
Shilton Industrial Estate,
Shilton, Coventry, England
CV79JY
Phone: +44 (0) 2476 614700
Fax: +44 (0) 2476 614710

AUSTRALIA, NEW ZEALAND, OCEANIA (DISTRIBUTOR)

P.O. Box 295
Mordialloc Victoria 3195
Australia
Phone: 03 9586 6330
www.premiermounts.com.au



TABLE OF CONTENTS

Warning Statements 3

Parts List 4

Installation Tools 4

Wood Stud Installation 5

Optional Concrete Installation 5

AM2/AM2-B Installation 6

AM2/AM2-B Adjustment 6

Attaching the Display 7

UFP-220 Adapter Plate 7

AM2/AM2-B Tension Adjustment 7

Technical Specifications 8

PREMIER MOUNTS

LIMITED LIFETIME WARRANTY

What and Who is Covered by this Limited Warranty and for How Long

Premier Mounts warrants this product to be free from defects in material and workmanship for the lifetime of the original owner of this product. The limited warranty is valid only for the original purchaser of the product.

What Premier Mounts Will Do

At the sole option of Premier Mounts, Premier Mounts will repair or replace any product or product part that is defective. If Premier Mounts chooses to replace a defective product or part, a replacement product or part will be shipped to you at no charge, but you must pay any labor costs.

What is Not Covered; Limitations

PREMIER MOUNTS DISCLAIMS ANY LIABILITY FOR DAMAGE TO MOUNTS, ADAPTERS, DISPLAYS, PROJECTORS, OTHER PROPERTY, OR PERSONAL INJURY RESULTING, IN WHOLE OR IN PART, FROM IMPROPER INSTALLATION, MODIFICATION, USE OR MISUSE OF ITS PRODUCTS.

PREMIER MOUNTS DISCLAIMS ALL OTHER WARRANTIES, EXPRESS OR IMPLIED, INCLUDING WARRANTIES OF MERCHANTABILITY AND FITNESS FOR A PARTICULAR PURPOSE. PREMIER MOUNTS IS NOT RESPONSIBLE FOR INCIDENTAL OR CONSEQUENTIAL DAMAGES, INCLUDING BUT NOT LIMITED TO, INABILITY TO USE ITS PRODUCTS OR LABOR COSTS FOR REMOVING AND REPLACING DEFECTIVE PRODUCTS OR PARTS. SOME STATES DO NOT ALLOW THE EXCLUSION OR LIMITATION OF INCIDENTAL OR CONSEQUENTIAL DAMAGES, SO THE ABOVE LIMITATION OR EXCLUSION MAY NOT APPLY TO YOU.

What Customers Must Do for Limited Warranty Service

If you discover a problem that you think may be covered by the warranty you MUST REPORT it in writing to the address below within thirty (30) days. Proof of purchase (an original sales receipt) from the original consumer purchaser must accompany all warranty claims. Warranty claims must also include a description of the problem, the purchaser's name, address, and telephone number. General inquiries can be addressed to Premier Mounts Customer Service at 1-800-368-9700. Warranty claims will not be accepted over the phone or by fax.

Premier Mounts
Attn: Warranty Claim
3130 E. Miraloma Avenue
Anaheim, CA 92806

How State Law Applies

THIS WARRANTY GIVES YOU SPECIFIC LEGAL RIGHTS, AND YOU MAY ALSO HAVE OTHER RIGHTS WHICH VARY FROM STATE TO STATE.



Warning Statements

WARNING: THE WALL STRUCTURE MUST BE CAPABLE OF SUPPORTING AT LEAST FIVE TIMES THE WEIGHT OF THE DISPLAY IF NOT, THE WALL MUST BE REINFORCED. PROPER INSTALLATION PROCEDURE BY A QUALIFIED SERVICE TECHNICIAN, AS OUTLINED IN THE INSTALLATION INSTRUCTIONS, MUST BE ADHERED TO. FAILURE TO DO SO COULD RESULT IN SERIOUS PERSONAL INJURY, OR EVEN DEATH. THE MAXIMUM WEIGHT THAT CAN BE USED WITH THIS MOUNT IS 50LBS. IF THIS WEIGHT IS EXCEEDED, DAMAGE TO THE DISPLAY AND/OR THE MOUNT MAY OCCUR.

WARNING: SAFETY MEASURES MUST BE PRACTICED AT ALL TIMES DURING THE INSTALLATION OF THE PREMIER MOUNTS PRODUCT YOU HAVE PURCHASED. IF YOU HAVE ANY QUESTIONS OR ARE UNCLEAR AS TO PROPER INSTALLATION PROCEDURES, PLEASE CONTACT A QUALIFIED SERVICE TECHNICIAN OR PREMIER MOUNTS AT (800) 368-9700. FAILURE TO FOLLOW PROPER INSTALLATION PROCEDURES AS PROVIDED IN THE INSTALLATION INSTRUCTIONS COULD RESULT IN SERIOUS PERSONAL INJURY, OR EVEN DEATH.

WARNING: PRIOR TO THE INSTALLATION OF ANY PREMIER MOUNTS PRODUCT, THE INSTALLATION INSTRUCTIONS MUST BE READ AND FOLLOWED TO PREVENT PERSONAL INJURY AND PROPERTY DAMAGE. SAVE THEM IN AN EASILY ACCESSIBLE LOCATION FOR FUTURE REFERENCE.



Indicates that the power plug is to be disconnected from the power outlet.



Safety precautions must be taken at all times.



Proper safety gear and tools must be used for the installation procedure to prevent personal injury. These include safety glasses or goggles among other things.



Any ceiling or wall structure where you intend to install your Premier Mounts product must be capable of supporting at least five (5) times the weight of the projector or display that you intend to mount. If not, the ceiling or walls must be reinforced.



If you are installing your product on a ceiling with wooden rafters or a wall with wooden studs, screws must be driven into the 'dead center' of each rafter or stud. 'Dead center' must be confirmed with an appropriate tool prior to installation.



Do not install a Premier Mounts product on a structure that is prone to vibration, movement or risk of impact; or too close to a heater, fireplace, air conditioner or other source of direct heat; or in direct sunlight. Such installations could result in damage to the projector/display and/or to the mounting surface and could increase the risk of fire.



At least two capable people must perform the installation procedure. One person cannot safely install, remove, or replace a flat panel display; such an attempt may result in dropping the display. Injury and/or damage can result from dropping or mishandling a projector/display.



Recommended mounting surfaces: wooden studs and solid-flat concrete. If the mount is to be installed on any surface other than wooden studs, use suitable hardware (which is commercially available).











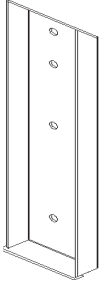

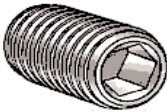
Contact Premier Mounts with any technical/installation questions.

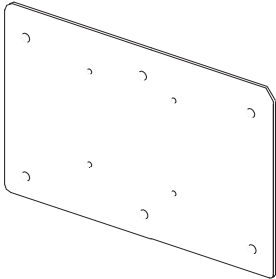

Parts List

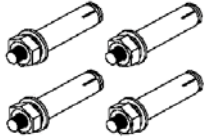
NOTE: This mount is shipped with all installation hardware and components. Make sure that none of these parts are missing and/or damaged before beginning installation. If there are parts missing and/or damaged, please stop and contact Premier Mounts - (800) 368-9700.

<p>Mounting Backplate (Qty 1)</p> 	<p>AM2 Swingout Arm (Qty 1)</p> 
<p>M6 x 35mm Set Screw (Qty 1)</p> 	<p>#14 x 2" Wood Screws (Qty 4)</p> 
<p>M3 Allen Wrench</p> 	<p>M4 x 10mm Phillips Head Screws (Qty 4)</p> 
<p>UFP-220 Adapter Plate (Qty 1)</p> 	<p>M4 x 5mm Phillips Head Screws (Qty 4)</p> 
	<p>1/4" x 1-1/2" Wedge Anchors (Qty 4). These are used only for concrete applications.</p> 
<p>14mm Socket (Qty 1)</p> 	<p>M4 x 10mm Phillips Flat Head Screws (Qty 6)</p> 

Installation Tools

- | | |
|-------------------------------------|----------------------------------|
| Phillips Head Screw Driver | Portable Drill |
| Soft Material/Blanket | Pencil |
| 5/16" Drill Bit (for wedge anchors) | 1/8" Drill Bit (for wood screws) |
| Level | Tape Measure |
| Socket Wrench | 14mm Socket (Supplied) |
| Stud Finder (Sold Separately) | M3 Allen Wrench (Supplied) |



Wood Stud Installation



Determine where the mount location will be. Use a stud finder to locate the nearest wall stud.

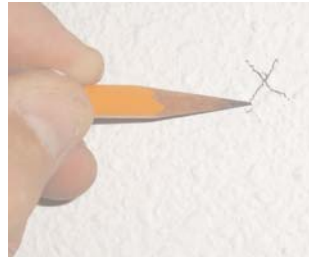

Once the stud has been located, use a pencil to mark the center of the stud.



Use the level (supplied) to make sure the backplate is level from top to bottom. Place the back plate over the first hole, and use a pencil to mark the rest of the holes.



Use a drill and a 1/8" drill bit to pre-drill the mounting holes.



Use the provided wood screws to attach the back plate to the mounting surface.

Optional Concrete Installation



Drill the mounting holes where the marks were made with a pencil. Use a 5/16" concrete drill bit (commercially available).



Once the holes have been drilled, place the wedge anchor into the hole. Using a hammer, gently tap into place.



Correctly seated wedge anchor bolt.



Place the backplate over the wedge anchors once the wedge anchors have been correctly inserted into the mounting surface. Place the washer, locking washer and nut onto the threaded shaft and tighten.



AM2/AM2-B Installation

The reverse side of the mount must be mounted to the backplate that is attached to the wall. The back of the mount contains an elongated rectangle. The back plate receptacle must be placed over the top of the back plate, so that the entire mount “hangs” on the back plate.

WARNING: Failure to fully tighten the locking screw may result in possible damage to your display.

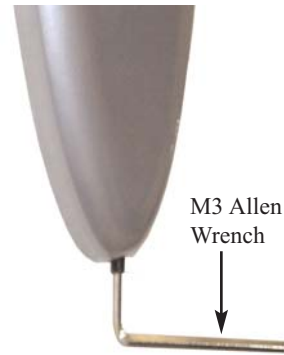

Use the M3 Allen Wrench (supplied) to tighten the locking screw that is located on the bottom of the mount base. This locking screw will prevent the mount and display from being lifted off of the wall plate.

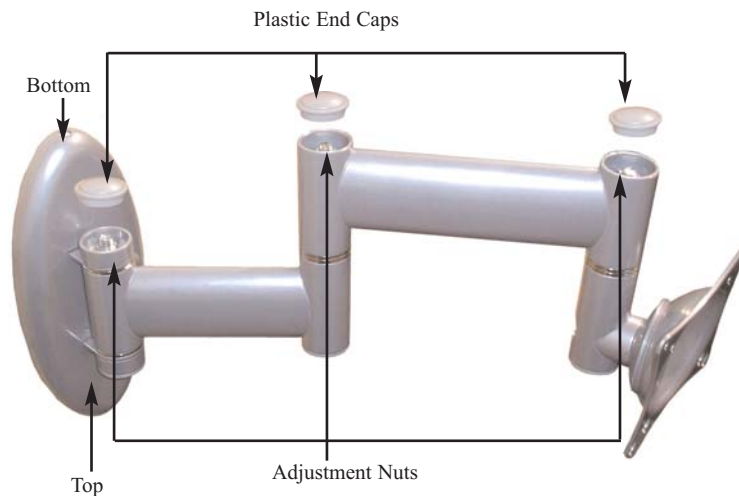

Adjusting the Swingout Arm

NOTE: The mount shown in this illustration is upside down to access the adjustment nuts.

This unit comes pre-tensioned at the factory. To adjust the swingout arm so that there will not be any movement, perform the following steps:

1. Remove the Plastic End Caps.
2. Take a 14mm socket and ratchet and tighten the nut.
3. Tighten, or loosen, each joint to the user’s satisfaction.
4. Replace the Plastic End Caps.

NOTE: The tilt/pivot adjustment nut is located on the back of the tilt/pivot mount.



AM2/AM2-B Tension Adjustment

To adjust the tension of the AM2/AM2-B, use the 14mm socket (supplied) and Allen Wrench. The tension nut is located on the back of the AM2/AM2-B neck.

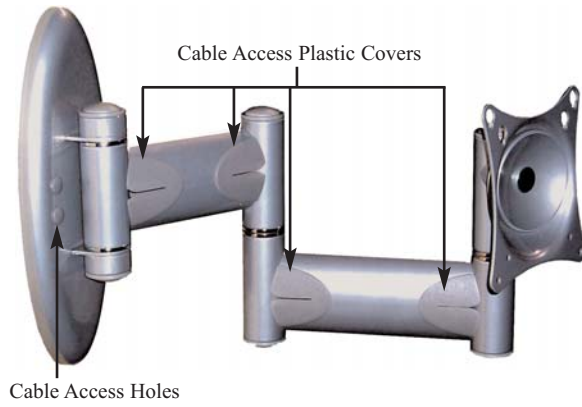

Cable Access

Please refer to figure above for the correct way to route existing cables.

1. After the monitor has been mounted, remove the cable access plastic covers.
2. Route any existing cables through these access holes.
3. Once complete, re-insert the plastic covers.

Attaching the Display

1. Loosely attach two (2) M4 x 10 phillip screws to the top two mounting points on the display.
2. Insert the head of the screws through the keyhole slots on the AM2/AM2-B and then secure the bottom two (2) M4 x 10 phillip crews to secure the flat panel to the mount, then tighten the upper M4 screws.

CAUTION: Do not over tighten the M4 screws.

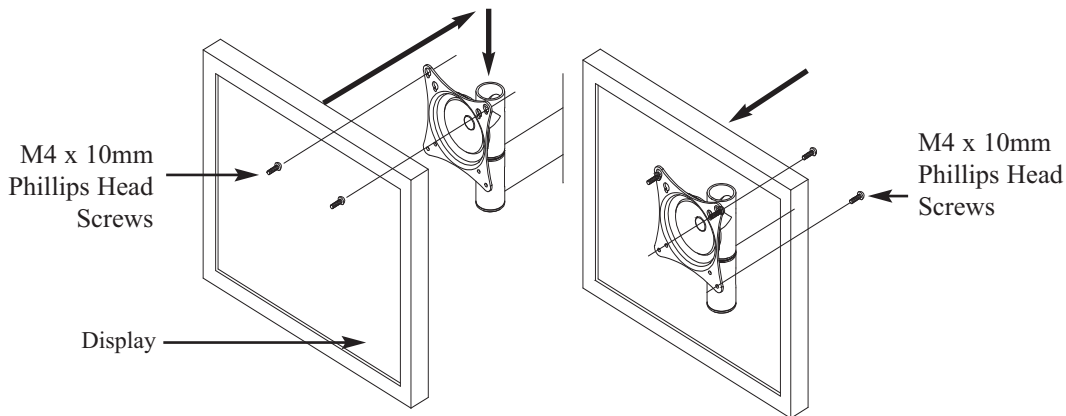

UFP-220 Adapter Plate

NOTE: If your flat panel has a 200mm x 100mm mounting pattern, the UFP-220 Adapter Plate must be used.

1. Attach the UFP-220 Adapter Plate to the back of the display using the six (6) M4 x 10mm flat head screws.
2. Attach the AM2/AM2-B mounting plate to the back of the UFP-220 using the four (4) M4 x 5 mm screws.

CAUTION: DO NOT OVERTIGHTEN THE SCREWS.

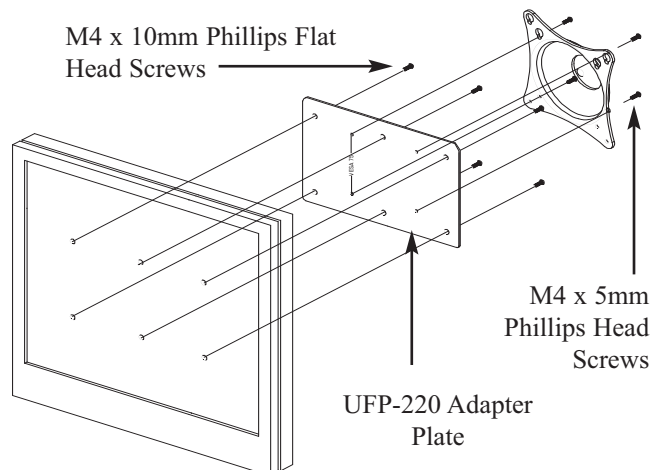



Technical Specifications

All measurements are in inches(mm).

